

DEPARTMENT OF WOMEN'S AND CHILDREN'S HEALTH
Karolinska Institutet, Stockholm, Sweden

EFFECT OF SELECTIVE ESTROGEN
RECEPTOR MODULATORS (SERMS)
ON GROWTH PLATE CARTILAGE

Elham Karimian



**Karolinska
Institutet**

Stockholm 2010

Cover photo: Masson's trichrome staining of the rabbits growth plates treated with resveratrol.

All previously published papers were reproduced with permission from the publisher.

Published and printed by Karolinska University Press
Box 200, SE-171 77 Stockholm, Sweden
© Elham Karimian, 2010
ISBN 978-91-7409-904-1

ABSTRACT

More than 300 years ago Dr. Stephen Hales drilled holes in the shaft of chicken bones and noted that as the animal grew, the distance between these holes remained constant. This led him to conclude that longitudinal bone growth occurs at the end of the long bones, rather than in the middle. During the subsequent centuries, employing increasingly sophisticated approaches, we have learned that bone elongation involves cells located in the cartilage of the epiphyseal growth plate at the end of the long bones.

The transient epiphyseal growth plate consists of cartilage present only during the growth period. Cell proliferation and differentiation and subsequent bone formation in this cartilage are controlled by various endocrine, autocrine and paracrine factors which finally eliminate the cartilaginous tissue and promote epiphyseal fusion. It is well known that sex steroids in particular estrogens, play an important role in longitudinal bone growth during puberty. High doses of estrogen therapy can reduce the final height of an individual, but such treatment is also associated with severe side-effects. At the same time, attenuation of estrogen production by aromatase inhibitors increases this final height, inhibiting bone turnover, which influences bone architecture and may increase the risk for vertebrae fracture.

Selective estrogen receptor modulators (SERMs), which display either estrogenic and or anti-estrogenic effects, bind to estrogen receptors ER(s) with different affinities and subsequently recruit co-modulators of transcription in a tissue specific manner. Therefore, our hypothesis is that SERMs may prove to be valuable tools for modulating longitudinal bone growth.

First, we examined the effect of tamoxifen, a first generation SERM, on the longitudinal growth of fetal rat metatarsal bones, in culture. We found that this drug retards such growth in a dose-dependent manner, as a result of specific elimination of chondrocytes, primarily in the resting zone of the growth plate, by apoptosis (**Paper I**).

To extend these findings to the *in vivo* situation and at the same time evaluate the long-term effects of tamoxifen on bone growth and mineralization, we used young male rats. At a clinically relevant dose tamoxifen causes persistent retardation of longitudinal and cortical radial bone growth in these animals (**Paper II**).

Next in attempt to improve clinical approaches to altering growth plate cartilage and longitudinal bone growth by reducing side-effects, we investigated *Trans*-resveratrol (3, 5, 4'-trihydroxystilbene), a phytoSERM with a polyphenolic structure that is produced by a variety of plants in response to infection. We found that in ovariectomized rabbits, resveratrol improves both axial and appendicular bone growth, an effect associated with an increased number and size of hypertrophic chondrocytes and attenuation of the expression of VEGF by these same cells. At the same time, the serum level of IGF-I was unaltered by treatment with this phytoSERM (**Paper III**).

Finally, we developed new culturing conditions that allow long-term study of the growth of postnatal rat metatarsal bones *ex vivo*. This model can be employed to characterize persistent long-term growth in culture under serum-free conditions, and responses to known suppressors and stimulators of bone growth, thereby offering the possibility to study the phenomenon of "catch-up" growth *in vitro*. This system also facilitates the screening of the effects of various SERMs at different concentrations on postnatal bones, the growth of which is regulated in a different manner than that of fetal bones (**Paper IV**).

The studies described here demonstrate that SERMs have the potential to influence growth plate cartilage in such a manner as to affect the longitudinal bone growth.

LIST OF PUBLICATIONS

- I. Andrei S. Chagin, **Elham Karimian**, Farasat Zaman, Masaharu Takigawa, Dionisios Chrysis, Lars Sävendahl. Tamoxifen induces permanent growth arrest through selective induction of apoptosis in growth plate chondrocytes in cultured rat metatarsal bones. *Bone* 40 (2007) 1415–1424

- II. **Elham Karimian**, Andrei S. Chagin, Jennifer Gjerde, Ernst A Lien, Claes Ohlsson and Lars Sävendahl. Tamoxifen Impairs Both Longitudinal and Cortical Bone Growth in Young Male Rats. *Journal of Bone and Mineral Research* 23 (2008) 1267-1277

- III. **Elham Karimian**, Chen Liu, Andrei S Chagin, Karin Samuelson, Claes Ohlsson, and Lars Sävendahl. Resveratrol Treatment Delays Growth Plate Fusion and Improves Bone Growth in Ovariectomized Rabbits. *Submitted for publication*

- IV. Andrei S. Chagin, **Elham Karimian**, Katja Sundström, Emma Eriksson and Lars Sävendahl. Catch-up growth after dexamethasone withdrawal occurs in cultured postnatal rat metatarsal bones. *Journal of Endocrinology* 204 (2010), 21–29

TABLE OF CONTENTS

1	Introduction.....	7
1.1	Longitudinal bone growth	8
1.1.1	Bone formation and skeletogenesis	8
1.1.2	Structure of the growth plate.....	10
1.1.3	Elimination of hypertrophic chondrocytes	11
1.2	Local regulation of the growth plate	12
1.2.1	Bone morphogenic proteins (BMPs)	12
1.2.2	Fibroblast growth factors (FGFs).....	13
1.2.3	Signaling by Indian hedgehog (Ihh)/ Parathyroid hormone related-protein (PTHrP).....	13
1.3	Systemic regulation of the growth plate	14
1.3.1	The GH/IGF-I system.....	14
1.3.2	Glucocorticoids.....	16
1.3.3	Androgens.....	17
1.3.4	Estrogens.....	17
1.3.5	Selective estrogen receptor modulators (SERMs).....	22
2	Aims	26
3	Methodological considerations	27
3.1	Model system.....	27
3.1.1	A cell line (Paper I)	27
3.1.2	Organ culture of metatarsal bones (Papers I, III and IV)	27
3.1.3	Male Sprague-Dawley rats (Paper II)	28
3.1.4	Ovariectomized New Zealand white rabbits (Paper III)	29
3.2	Analyses of Bone growth and structure	29
3.2.1	Dual X-ray absorptiometry (DXA) (Paper II)	29
3.2.2	Radiographic imaging (Papers II and III).....	29
3.2.3	Peripheral quantitative computed tomography (pQCT) (Papers II and III).....	30
3.2.4	Testing Mechanical properties (Paper II)	30
3.3	Quantitative histology of the growth plate (Paper II and III)	30
3.4	Monitoring Cell proliferation	31
3.4.1	Labeling 5-bromo-2'-deoxyuridine (BrdU) (Papers I-IV) ..	31
3.4.2	The WST-1 cell viability assay (Paper I).....	31
3.5	Detection of Apoptosis	31
3.5.1	The TUNEL procedures (Papers I-IV)	31
3.5.2	Cell death ELISA (Paper I)	32
3.5.3	Double-labeling with Annexin-V and propidium iodide (Paper I)	32
3.5.4	Fluorometric assay for caspase activity (Paper I).....	32
3.6	Determination of levels of protein expression	33
3.6.1	Immunohistochemistry (IHC) (Papers I-IV)	33
3.6.2	Western immunoblotting (Paper I)	33
3.7	High-performance liquid chromatography-tandem mass spectrometry (LC-MS-MS) (Paper II)	34
4	Results and Discussion	35

4.1	Tamoxifen inhibits longitudinal bone growth permanently <i>in vitro</i> (Paper I)	35
4.2	Tamoxifen impairs bone growth in growing rats (Paper II)	36
4.3	Resveratrol delays growth plate fusion and improve bone growth in rabbits (Paper III)	39
4.4	Catch-up growth occurs in postnatal rat metatarsal bones cultured <i>in vitro</i> (Paper IV)	42
5	Conclusions	45
6	Acknowledgements	46
7	References	49

LIST OF ABBREVIATIONS

AF1	Activation function-1
AIs	Aromatase inhibitors
ALT	Alanine transaminase
BMI	Body-mass index
BMD	Bone mineral density
BMP	Bone morphogenic protein
BrdU	5-Bromo-2'-deoxyuridine
Ca ⁺²	Calcium ion
DXA	Dual X-ray absorptiometry
DHT	Dihydrotestosterone
E2	17 β -Estradiol
ECM	Extracellular matrix
ER	Estrogen receptor
ERE	Estrogen response elements
FGF	Fibroblast growth factor
GH	Growth hormone
GnRH	Gonadotrophin-releasing hormone
GPR30	G protein-coupled receptor
HPLC	High-performance liquid chromatography
IGF-I	Insulin-like growth factor-I
Ihh	Indian hedgehog
ISS	Idiopathic short stature
MAPK	Mitogen-activated protein kinase
MMPs	Matrix metalloproteinase
Pi	Phosphate ion
pQCT	Peripheral quantitative computerized tomography
PTHrP	Parathyroid hormone-related peptide
SDS	Standard deviation score
SERM	Selective estrogen receptor modulator
TUNEL	Terminal deoxynucleotidyl transferase-mediated deoxy-UTP nick-end labeling
VEGF	Vascular endothelial growth factor
WT	Wild-type

1 INTRODUCTION

The bone and cartilage tissues of our skeletal system provide not only mechanical support, but also protect the vital organs of the body, including the: heart, lungs and brain. Consequently, normal growth and development of skeletal bone is essential. These processes involve two different pathways: membranous ossification, which gives rise to calvarial bones directly from osteoblastic cells; and endochondral ossification, which is responsible for the growth of long bones such as those in the limbs, the vertebrae and certain of the bones in the skull.

Growth is influenced by numerous factors, including; genetic background, nutritional and socioeconomic status, endocrine function, and psychosocial security (Tanner and O'Keeffe, 1962; Mascie-Taylor, 1991). In light of the differences between various ethnic groups in this respect, growth must be defined in relationship to the relevant reference population. In general, an individual whose height differs by more than two standard deviation (SD) from the mean of this reference population (*i.e.*, a child with a height above the 97th percentile of the growth curve) is considered too tall, just as a child shorter than the 3rd percentile is considered to be too short.

One of the most common reasons for referral of patients to pediatric endocrinologists is short stature, *i.e.*, a height significantly below the target level and an abnormally slow increase in height. In the majority of such patients short stature is a normal variation or due to genetic-familial factors (Joseph E Raine, 2005). At present, few growth-promoting therapies are available for clinical use.

Growth hormone (GH) is licensed only for the treatment of certain causes of short statures and is, moreover, costly and inconvenient requiring daily injection. Recently, recombinant insulin-like growth factor-1 (IGF-I) has been licensed for the treatment of cases that do not respond to GH (*i.e.*, the Laron syndrome) (Collett-Solberg and Misra, 2008), but the efficacy of this factor in treating other causes of severe short stature remains to be evaluated. The use of analogues of gonadotrophin-releasing hormone (GnRH) to arrest pubertal development and thereby prolong pubertal growth do not appear promising (Joseph E Raine, 2005). Although attenuation of estrogen biosynthesis by aromatase inhibitors has the potential to increase predicted adult height in boys with idiopathic short stature (Hero et al., 2005; Mauras et al., 2008), the associated occurrence of vertebral deformities and disturbed vertebral-body

(Hero et al., 2009) raise concerns about bone architecture and fracture risk following estrogen deprivation.

Excessive growth and abnormally tall stature have been of less concern, but, nonetheless, cause practical problems and increase the risk for trunk abnormalities (i.e., kyphosis and scoliosis). Therefore, appropriate treatment to limit adult height is also desirable (Hazebroek-Kampschreur et al., 1994) and several strategies have been proposed in this connection. High-dose administration of sex steroids has been employed for nearly 60 years (Goldzieher, 1956) to reduce growth rate and induce growth plate fusion. In girls, high doses of estrogens do result in a time- and dose-dependent decrease in adult height (Prader and Zachmann, 1978; Ignatius et al., 1991). However, these treatments have serious side-effects, including decreased fertility (Venn et al., 2004) and a fear of elevated long-term risk for cancer (Panteon et al., 1988; Werder et al., 1990; Drop et al., 1998). Suppression of GH levels should theoretically reduce growth rate and may reduce final height. Although analogues of somatostatin are effective in reducing GH secretion in children of constitutionally tall stature, these drugs also have certain undesirable side-effects (Hindmarsh et al., 1990; Carel et al., 2009).

Possible substitution therapy or future strategies for treating such growth disorders, which are the concern of the present study, will be discussed later. First, it is of value to review what is presently known about the physiology of bone growth, the structure of the growth plate and, systemic and local regulators of longitudinal bone growth.

1.1 LONGITUDINAL BONE GROWTH

During the three stages of human linear growth, i.e., infancy, childhood and puberty, growth is regulated differently. During infancy, when the child may grow as much as 25 cm per year, growth is regulated primarily by nutrition. However, with time, nutrition becomes less important and the GH-IGF-I axis becomes the principal regulator of childhood growth, when the annual increase in height varies from 4 to 8 cm. At puberty, the dramatic increase in growth referred to as the adolescent growth spurt, as well as the manifestation of secondary sexual characteristics, are the result of activation of the hypothalamic-pituitary-gonadal system (Joseph E Raine, 2005).

1.1.1 Bone formation and skeletogenesis

Skeletal formation begins with condensations of mesenchymal cells in regions of the embryo destined to eventually become bone (Fig. 1a). The appearance of markers for chondrocyte differentiation is the first indication of endochondral

development: the master gene driving this differentiation, SOX9, activates its target genes in chondrogenic cells, thereby stimulating secretion of an extracellular matrix rich in cartilage proteins (i.e., types II, IX and XI collagen, aggrecan and cartilage oligomeric matrix protein) (Morris, 2002) (Fig.1b). In the center of the cartilage anlagen formed, the chondrocytes undergo terminal differentiation, which involves down-regulation of SOX9 and other cartilage-specific genes and up-regulation of RUNX2 and other factors specific for more differentiated chondrocytes (Kronenberg, 2003; Horton, 2006).

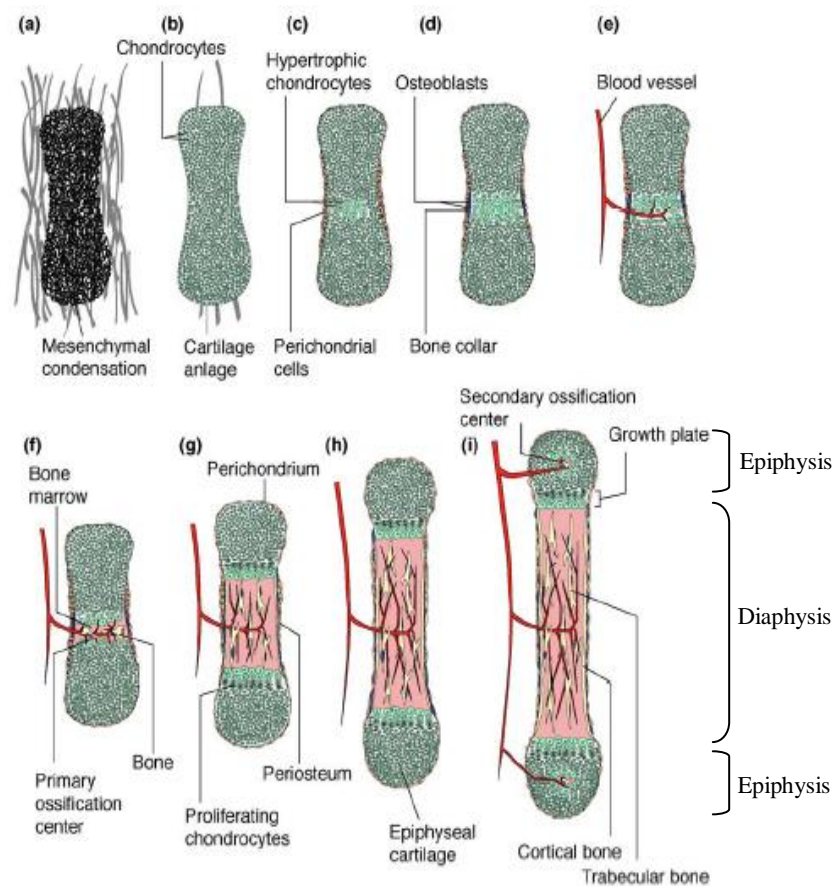

Figure 1. Endochondral bone development (reproduced from Horton WA, 2006 by permission)

In parallel, mesenchymal cells surrounding the cartilage anlagen differentiate into osteoblasts that form a perichondrial collar of membranous bone surrounding the center of the anlagen (Figure 1c and 1d) (Kronenberg, 2003; Long et al., 2004; Horton, 2006). This collar appears to act as a staging area for the subsequent invasion of the cartilage anlagen, which leads finally to the formation of primary ossification centers (Figure 1f), which spread within the cartilage anlagen

(Morris, 2002; Horton, 2006) and makes the diaphysis. Most of the cartilage tissue is converted to bone, except for that close to the epiphysis, where chondrocytes proliferate and synthesize the cartilage matrix prior to further differentiation to pre-hypertrophic and terminally mature chondrocytes (Figures 1g–i). Subsequently, secondary centers of ossification form in the epiphyseal cartilage (Figure 1i), which is eventually converted into bone, with the exception of a thin layer of articular cartilage at the surface of the joint.

Bone elongation occurs through proliferation and differentiation of the cells located in the cartilage of the epiphyseal growth plates at the ends of the long bones. These plates are present only during the growth period and vanish when sexual maturation is complete.

1.1.2 Structure of the growth plate

The growth plate is divided into three well-defined zones. Closest to the epiphysis, the **reserve zone** (also known as the germinal zone) contains single or pairs of small, uniformly round and relatively quiescent cells embedded in a large volume of extracellular matrix (ECM) (Ballock and O'Keefe, 2003; Melrose et al., 2008) (Fig 2). Immediately beneath this reserve zone lies the **proliferative zone**, where the chondrocytes flatten, begin to divide and form ladders parallel to the bone alignment, and synthesize collagen of types II and XI (Ballock and O'Keefe, 2003) (Fig 2). In the underlying zone of maturation, referred to as the **hypertrophic zone**, the chondrocytes which are larger and more swollen than in the other zones, begin their terminal differentiation. The characteristic features of these hypertrophic chondrocytes include a lack of cell division, a pronounced increase in alkaline phosphatase activity and synthesis of large amounts of various elements of the ECM, including type-X collagen, a unique short-chain collagen found only in this zone (O'Keefe et al., 1994; Karimian et al., 2008) (Fig 3). This morphological transformation is regulated by various hormones and growth factors.

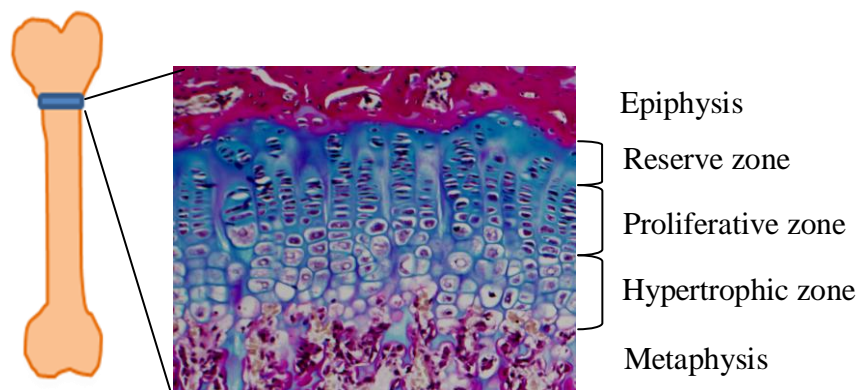

Figure 2. The organization of chondrocytes in the growth plate

1.1.3 Elimination of hypertrophic chondrocytes

There are several proposals concerning the ultimate fate of terminally differentiated chondrocytes in the growth plate, as well as their role in the generation of endochondral bone.

1.1.3.1 *Transdifferentiation*

Transdifferentiation, a process by which highly differentiated cells undergo remarkable changes in shape, size and function, would involve conversion of chondrocytes to osteoblasts dedifferentiation and subsequent redifferentiation (Shapiro et al., 2005). Certain post-mitotic cells are known to be capable of changing their phenotypes in rather dramatic ways, e.g., skin cells have the ability to differentiate into neural progeny (Toma et al., 2001). Most of the evidence in favor of transdifferentiation and reprogramming of epiphyseal chondrocytes is based on studies involving cell and organ cultures. As early as 1932, Honor Fell observed that chondrocytes from young chicks in culture appear to convert into bone cells (Fell, 1932). Later on, the occurrence of costochondral rib and bone formation *in vitro* led to the conclusion that uncommitted (stem) cells in cartilage provide a rich source of osteoprogenitors (Holtrop, 1966). This conclusion was supported by subsequent investigations (Silbermann et al., 1987; Livne et al., 1988; Weiss et al., 1988a; Weiss et al., 1988b; Ben-Ami et al., 1993), which together provide strong support for the transition of chondrocytes into osteoblasts.

1.1.3.2 *Apoptosis or type-I programmed cell death*

The condensed cells at the chondro-osseous junction, first identified and designated as “dark chondrocytes” by Farnum and Wilsman (Farnum and Wilsman, 1989b) have been shown to be undergoing a special form of apoptosis referred to as chondroptosis (Roach et al., 2004). Programmed cell death is clearly an essential event in the development, growth and maintenance of tissue homeostasis in multicellular organisms (Ishizaki et al., 1994; Ishizaki et al., 1995; Zuzarte-Luis and Hurle, 2002). Different types of apoptotic cells have been identified in growth plate cartilage by various techniques and investigators (Hargest et al., 1985; Farnum and Wilsman, 1987; 1989a; Bronckers et al., 1996; Aizawa et al., 1997).

Interestingly, after post-mitotic hypertrophic chondrocytes become terminally differentiated, they are susceptible to numerous pro-apoptotic stimuli at the chondro-oseous junction. During endochondral bone formation, septoclasts (Lee et al., 1995) lyse the cartilage matrix proteins, which produces high local concentrations of ions, glycans and peptides, some of which are permissive to chondrocyte

apoptosis. In this context the most important matrix element is the Ca^{2+}/Pi ion pair. Pi has been shown to exert potent apoptogenic effects on isolated chick chondrocytes (Mansfield et al., 1999; Magne et al., 2003) and animal studies have confirmed the key role played by Ca^{2+} and Pi as regulators of apoptosis in growth plate chondrocytes. For instance, in vitamin D-deficient mice, although the proliferative and resting zones in the rachitic growth plate are normal, the hypertrophic zones are greatly enlarged (Donohue and Demay, 2002). An additional factor that might control chondrocyte apoptosis is the local level of O_2 with the central player in this connection being the transcription factor, hypoxia-inducible factor (HIF). When the level of oxygen falls, HIF is stabilized and activates several genes, including the one encoding VEGF. In other tissues ischemia-reperfusion injury causes massive apoptosis (Toledo-Pereyra et al., 2004) while in the growth plate the low oxygen tension serves initially to enhance cell survival, since hypoxia attenuates chondrocyte sensitivity to apoptosis (Bacon and Harris, 2004). Invasion of blood vessels into the cartilage of the chondro-osseous junction (possibly related to HIF-dependent expression of VEGF) causes a sudden elevation in the local oxygen tension and may thereby precipitate cell death (Shapiro et al., 2005).

1.1.3.3 Autophagy or type II programmed cell death

An electronmicroscopic study of hypertrophic chondrocytes in neonate rabbits revealed compartmentalization of the cytoplasm into large vacuoles by the endoplasmic reticulum, a sign of degradation (Roach and Erenpreisa, 1996; Erenpreisa and Roach, 1998). Morphologically, these dying cells contained autophagic vacuoles (autophagosomes), surrounded by double membranes, organelles designed for self-degradation. This process, through which cells consume themselves, can be activated by nutrient deficiency. However, in a recent investigation, Emons and colleagues (Emons et al., 2009) detected no signs of either classical apoptosis or autophagia in connection with fusion of the human growth plate.

1.2 LOCAL REGULATION OF THE GROWTH PLATE

Among the key para/autocrine regulators of bone formation are bone morphogenic proteins (BMPs), fibroblast growth factors (FGFs), hedgehog protein and parathyroid hormone-related peptide (PTHrP).

1.2.1 Bone morphogenic proteins (BMPs)

BMPs are growth and differentiation factors that play essential roles at every stage of endochondral bone development. Mice lacking BMPs and/or their receptors fail to extend mesenchymal condensations or achieve digit formation (Storm

and Kingsley, 1999; Baur et al., 2000; Pizette and Niswander, 2000). At later stages, these proteins are expressed in the perichondrium as well as hypertrophic and proliferative chondrocytes. BMP signaling enhances the expression of *Ihh* by prehypertrophic chondrocytes (Minina et al., 2001; Minina et al., 2002), thereby increasing both the rate of chondrocyte proliferation and the length of proliferative columns. Furthermore, *in vitro* these factors directly trigger chondrogenesis by human mesenchymal stem cells to induce the formation of hypertrophic chondrocytes (Steinert et al., 2009).

1.2.2 Fibroblast growth factors (FGFs)

Recent genetic studies have demonstrated that signaling by FGFs play a key role in regulating chondrocyte proliferation and differentiation and 22 different FGFs and four target receptor (FGFR) genes are expressed at every stage of endochondral ossification (Ornitz and Marie, 2002). Examination during the past decades of transgenic mice carrying a mutation in FGFR3, either locally in the growth plate or globally, have shown that this protein inhibits linear bone growth. Mutations in humans that potentiate the function of FGFR3 cause achondroplasia, hypochondroplasia and type I and II thanatophoric dysplasia (Horton et al., 2007). This inhibition of proliferation by FGF-signaling through FGFR3 involves, at least partially, activation of Janus kinase signaling and activator of transcription-1 (JAK-STAT1) (Colvin et al., 1996). The expression of FGFs and their receptors in postnatal growth plate cartilage suggests that these proteins contribute to growth plate senescence and thus help to determine the size of the adult skeleton (Lazarus et al., 2007).

1.2.3 Signaling by Indian hedgehog (Ihh)/ Parathyroid hormone related-protein (PTHrP)

Indian hedgehog (*Ihh*), the major regulator of bone development, orchestrates chondrocyte proliferation and differentiation, as well as osteoblast differentiation. During bone formation, *Ihh* is expressed and secreted by post-mitotic hypertrophic chondrocytes, simultaneously with expression of the parathyroid hormone-related protein receptor (PPR) (Fig 3). Its binding to the Patched-1 (Ptc-1), receptor leads to activation of Smoothed (Smo), an additional membrane protein required for the actions exerted by *Ihh* on cells. Active Smo subsequently triggers a cascade resulting in gene activation (Kronenberg, 2003).

Ihh can either act directly on chondrocytes to stimulate their differentiation, thereby regulating columnar cell mass in a manner independent of PTHrP (Kobayashi et al., 2005) or it can promote the synthesis of PTHrP by

periarticular and early proliferative chondrocytes (Lai and Mitchell, 2005) (Fig 3) to maintain the chondrocyte column. By binding to its receptor on proliferative and pre-hypertrophic chondrocytes, PTHrP delays the differentiation of chondrocytes into their hypertrophic stage, thereby shutting off production of *Ihh* by maintaining these cells in the proliferative phase (St-Jacques et al., 1999). The significance of this *Ihh*/PTHrP feedback loop for normal endochondral bone formation is enormous, as illustrated by the observation that disruption of any component of the system results in abnormal limb development (St-Jacques et al., 1999).

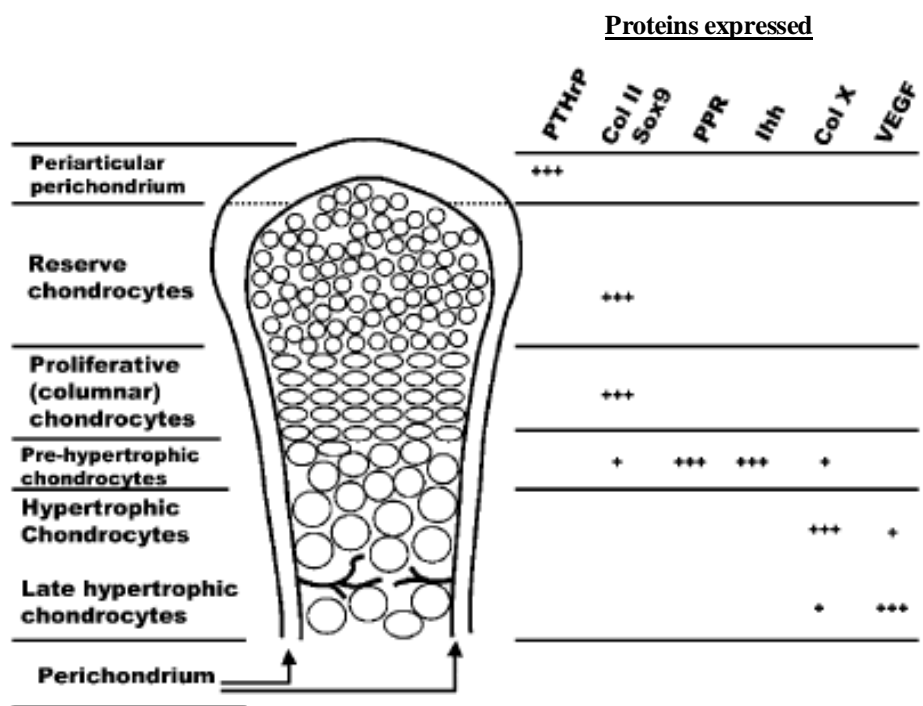

Figure 3. At different stages in their development growth plate chondrocytes exhibit different pattern of gene expression (reproduced from Lai LP and Mitchell, 2005 by permission)

1.3 SYSTEMIC REGULATION OF THE GROWTH PLATE

The key hormones that regulate longitudinal bone growth after birth are GH, IGF-I, insulin, glucocorticoids and thyroid hormones. However, during sexual maturation the sex steroids (androgens and estrogens) contribute significantly to this process.

1.3.1 The GH/IGF-I system

Starting during the second trimester of gestation growth hormone (GH) is synthesized by the anterior pituitary gland (Kaplan et al., 1972). The contributions of various factors, including hormones, neurotransmitters and metabolic modulators, to this regulation of GH synthesis in humans is illustrated in Figure 4. The physiological role of GH during fetal life is not well understood since, IGF-I and IGF-II which

independently of GH are key determinants of embryonic growth (Honnebier and Swaab, 1973), (Woods et al., 1996) although a later report did conclude that GH participates partially in fetal development (Waters and Kaye, 2002). On the other hand, following birth and throughout puberty and adulthood GH is well known to play a critical role in longitudinal skeletal growth (Isaksson et al., 1987; Guler et al., 1988; van der Eerden et al., 2003), exerting anabolic effects on trabecular and cortical bones (Giustina et al., 2008).

1.3.1.1 Functions of GH

GH can exert its effects directly by binding to a single-chain trans-membrane glycoprotein receptor (GHR) expressed at high levels in virtually all organs including growth plate cartilage (Gevers et al., 2002). At the same time, this hormone stimulates the production of IGF-I (formerly known as somatomedin C) in the liver (Melmed, 1999), which is the major target organ for GH and the principal site of IGF-I production. In addition, numerous extrahepatic tissues synthesize this hormone under the local control of various hormones.

Ninety-nine percent of all IGF-I found in the circulation is part of a 150-kD ternary complex also containing its dominant circulatory binding proteins, IGFBP-3 or IGFBP-5, and the acid labile subunit (ALS) (Boisclair et al., 2001). This ternary complex stabilizes IGF-I, prolonging its half-life and availability to target organs (Boisclair et al., 2001). Genetic ablation of individual components of this complex (i.e., liver-specific IGF-I, ALS, and IGFBP-3) only partially reduces serum levels of IGF-I and yields only minor skeletal abnormalities, indicating that the remaining serum IGF-I still exerts a substantial impact on the skeleton (Yakar et al., 2009), alternatively, that an elevation in the level of GH is sufficient to compensate for the defect. However, triple-knockout mice lacking liver-specific IGF-1, ALS, and IGFBP-3 exhibit a 97% reduction in their serum level of IGF-I and obvious destruction of bone (Yakar et al., 2009). At the same time, this destruction was markedly less severe than in IGF-I-null mice (Liu et al., 1993), strongly suggesting that local IGF-I and its complexes in tissues, rather than circulating IGF-I play a major role in skeletal development. Interestingly, a recent investigation by Stratikopoulos and colleagues (Stratikopoulos et al., 2008) showed that mice expressing IGF-I in their livers only attain no more than approximately 30% of the normal adult body size during postnatal development, i.e., that endocrine IGF-I plays a highly significant role in murine growth.

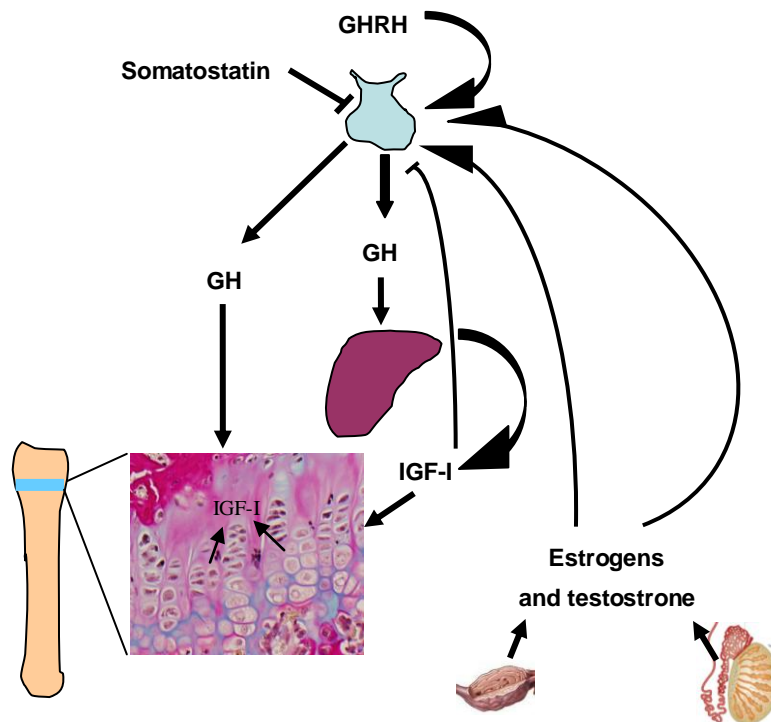

Figure 4. Schematic illustration of the regulators of GH synthesis and of the direct and indirect (via IGF-I signaling) effects of this hormone

1.3.2 Glucocorticoids

Exogenous glucocorticoids (GCs) often impair growth in both humans and animals (Altman et al., 1992; Allen, 1996; Chrysis et al., 2003), whereas, familial deficiencies in these steroids are associated with tall stature (Elias et al., 2000). The GC receptor is expressed in epiphyseal cartilage and cells of the femur bone of rat (Silvestrini et al., 1999), as well as in human growth plate cartilage (predominantly in the hypertrophic zone) and bone cells (osteoblasts and osteocytes) (Abu et al., 2000). Such observations suggest that the GCs exert direct effects on these tissues

By modifying the GH/IGF-I axis at different levels, even low doses of GCs suppress growth in both humans and animals (Allen, 1996; Smink et al., 2003). For example, Smink and coworkers (Smink et al., 2003), showed that such short-term treatment of mice retards growth significantly, decreases the width of the growth plate, and rate of chondrocyte proliferation, promotes apoptosis in hypertrophic chondrocytes and reduces the local level of IGF-I in the growth plate. Baron and colleagues (Baron et al., 1992) found that local infusion of dexamethasone into the epiphyseal growth plate of one leg of rabbits inhibits the growth of this leg and following dexamethasone withdrawal, catch-up growth in comparison to the contra-lateral leg occurs. These observations suggest that both the inhibitory effects of GCs

on growth, as well as catch-up growth following GC withdrawal are characteristic of the growth plate, although we cannot exclude the possibility that alterations in the GH/IGF system or any indirect effects might also play a role in this connection.

1.3.3 Androgens

Clearly, androgens are essential for male gonadal differentiation prior to birth, for sexual maturation and maintenance during and after puberty; and genital function and spermatogenesis during adulthood. However, their contribution to bone growth and development in men relative to that of estrogens remains unclear. The androgen receptor (AR) is expressed in the growth plate cartilage of several animal species, including the rat, rabbit and human (Abu et al., 1997; Ben-Hur et al., 1997; Nilsson et al., 2003a). Unilateral injection of testosterone enanthate into the epiphyseal growth plate of the rat tibia expands the width of this growth plate in comparison to the contralateral one (Ren et al., 1989), suggesting that androgens might act locally to stimulate bone growth. Moreover, non-aromatizable androgens such as dihydrotestosterone (DHT) and oxandrolone accelerate the rate of bone growth in patients without affecting systemic levels of GH (Stanhope et al., 1988; Veldhuis et al., 1997). The finding that oxandrolone does not influence the linear growth of cultures of fetal rat metatarsal bones (Chagin et al., 2009) supports the hypothesis that this androgen stimulates longitudinal bone growth in children by acting indirectly, rather than directly on growth plate chondrocytes (Chagin et al., 2009).

The evidence accumulated so far suggests that testosterone affects bone growth only after being aromatized to estrogen locally in the growth plate, a conclusion supported by the observation that aromatase P450 (CYP19) is expressed in growth plate chondrocytes (Oz et al., 2001). Furthermore, despite demonstrating normal levels of testosterone both aromatase-deficient males and females exhibit the characteristic features of estrogen deficiency, i.e., an unfused epiphysis, markedly delayed bone development and severe osteopenia in adulthood (Morishima et al., 1995; Carani et al., 1997). Together, these findings indicate that estrogens should not be considered to be solely female hormones, but more generally as sex steroids required for normal bone growth and development in both sexes.

1.3.4 Estrogens

1.3.4.1 Isoforms of the estrogen receptor

The physiological effects of estrogens are mediated primarily by two known nuclear receptors, estrogen receptor- α (ER α) (Green et al., 1986; Greene et al., 1986) and estrogen receptor- β (ER β) (Kuiper et al., 1996). ER α and ER β act as classical

ligand-activated transcription factors, residing in the cytosol until binding their ligand and then being translocated into the nucleus, where the estrogen-ER complex interacts with estrogen response elements (EREs) in the promoter regions of target genes. In addition, estrogens bind to subpopulations of ER α and ER β associated with the plasma membrane, thereby rapidly activating a variety of intracellular signaling cascades.

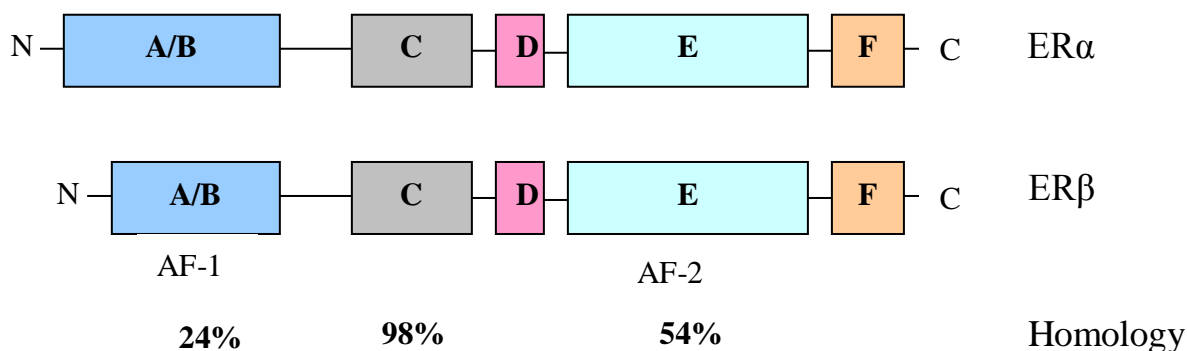

Figure 5. Structure of the estrogen receptors. These receptors contain 6 domains (A-F). From the N- to the C-terminus: the A/B domain mediates ligand-independent activation (AF-1). The C domain contains the DNA-binding domain that binds to EREs in target genes. The D domain is a hinge that provides flexibility between the C- and N- termini. The E and F domains contain the site that binds estrogen and estrogenic compounds. The AF-1 region at the N-terminus and the AF-2 region within the ligand-binding domain are involved in ligand-independent and ligand-dependent transcriptional activation, respectively. The percentage homology between the AB, C and E domains in these two isoforms is indicated below these domains.

Recently, a membrane-bound G protein-coupled estrogen receptor (GPR30) that rapidly mediates estrogen signalling has been identified (Revankar et al., 2005). This receptor is expressed at high levels in the hypertrophic zone and the expression level decreases during pubertal progression, suggesting that GPR30 is involved in modulating longitudinal bone growth (Chagin and Sävendahl, 2007). The observation that estrogen treatment of mice lacking this receptor (*GPR30* $-/-$), does not influence the height of the growth plate height or femur length (Windahl et al., 2009) indicates that GPR30 is required for normal estrogenic responses in the growth plate.

1.3.4.2 Mechanism of estrogen action at the cellular level

1.3.4.2.1 Classical mechanism of ligand-dependent ER action

Ligand binding to this receptor induces a conformational change that promotes ligand-receptor dimerization and this dimeric complex is then translocated into the nucleus, where it binds to a specific ERE in the promoter regions of responsive genes and activates their transcription.

1.3.4.2.2 ERE-independent activation of transcription

Certain studies have demonstrated that ERs can regulate transcription without binding directly to DNA, through protein-protein interactions with a complex of transcription factors that does have direct contact with the DNA. In this way ERs regulate the expression of a large number of genes that do not contain EREs. This mechanism which is common among members of the nuclear receptor superfamily, is often referred to as transcriptional cross-talk (Gottlicher et al., 1998).

1.3.4.2.3 Ligand-independent effects on transcription

Certain growth factors activate proteinkinase cascades that lead to the phosphorylation and activation of nuclear ERs bound to EREs.

1.3.4.2.4 Non-genomic action

Membrane E2-ER complexes activate proteinkinase cascades, thereby altering the functions of various cytoplasmic proteins and/or regulating gene expression through phosphorylation and activation of a transcription factors.

1.3.4.3 Endogenous production of estrogen

Chondrocytes appear to synthesize estrogen, both *in vivo* and *in vitro* (Oz et al., 2001; Sylvia et al., 2002; van der Eerden et al., 2002), in agreement with the observation that, P450 aromatase is expressed in the growth plate cartilage of both humans (Oz et al., 2001) and rats (van der Eerden et al., 2002; Chagin et al., 2006). Moreover, estrogen produced locally has been reported to be important for chondrocyte proliferation, protecting these cells from spontaneous cell death and thereby regulating longitudinal growth (Chagin et al., 2006).

1.3.4.4 Effects of estrogen deficiency on bone growth

The basic assumption that estrogen is the sex steroid primarily responsible for regulating pubertal growth in girls, while in boys this regulation is mediated primarily by androgen was challenged by Smith and his colleagues in the 1990's. These investigators described the unique case of a 28-year-old white man referred to the surgeon for progressive genu valgum, whose radiological examination revealed unfused epiphyses, a bone age of 15 years and a lumbar spine BMD that was 3 SD below the appropriate control mean. He was 204 cm tall, had an arm span of 213 cm and eunuchoid structure, and, due to his open epiphyses, was still growing slowly during the third decade of his life. Transdermal treatment with high doses of ethinyl estradiol for six months improved neither his total BMD nor advanced his bone age.

DNA analysis revealed a homozygous mutation in exon 2 of this patient's ER gene, resulting in a substitution of thymine for cytosine. Despite his normal serum levels of androgen, this genetic estrogen resistance was associated with a delay in skeletal maturation and continuing increase in height into adulthood (Smith et al., 1994). Histomorphometrical analysis of this patient's bones revealed that disruption of ER α actions markedly affected their mineral content and structure, but not the periosteal circumference (Smith et al., 2008).

Thereafter, in 1995, a similar phenotype appearance due to a homozygous mutation in exon IX of the aromatase P450 (CYP19) gene that led to high levels of androgens, but unlike the previous patient had an undetectable levels of estradiol in the serum was described (Morishima et al., 1995; Zirilli et al., 2009). In contrast to the patient described above, this man responded to therapy with conjugated estrogen. These observations indicate that androgen alone is not sufficient to promote skeletal maturation and maintain bone mass and that estrogen plays a pivotal role in bone mineralization in both males and females. The local expression of ERs by growth plate chondrocytes of various animal species (Nilsson et al., 1999; Nilsson et al., 2002) indicates that estrogens exert direct effects in this context.

1.3.4.5 Estrogen induces fusion of the growth plate in humans

Clinical cases of estrogen deficiency due to a defect in the synthesis of estrogen or function of its receptor clearly illustrate the significance of this sex hormone in regulating the pubertal growth spurt and growth plate fusion in both girls and boys (Smith et al., 1994; Morishima et al., 1995; Carani et al., 1997). When a child approaches the end of his or her period of growth, the growth plate thins and the rate of growth gradually declines, and finally ceases when the growth plate has vanished completely. High-dose treatment of children with estradiol promotes early fusion of the growth plate via the same processes that normally occur late in puberty (Drop et al., 1998).

The mechanism by which estrogens promote epiphyseal fusion is not well understood, but there is an alternative hypothesis based on a study in rabbits. Unlike what happens in small rodents, the growth plate in rabbits fuses at the time of sexual maturation or upon estrogen treatment (Weise et al., 2001). This hypothesis proposes that the growth plate undergoes programmed senescence, involving reductions in the rates of growth and chondrocyte proliferation, as well as the number and size of chondrocytes (Weise et al., 2001) Moreover, growth plate fusion appears

to be triggered when the proliferative capacity of the chondrocytes located there is fully exhausted.

1.3.4.6 Estrogen treatment for modulation of bone growth

Although high-dose treatment studies of constitutionally tall stature with estrogens have been effective (Goldzieher, 1956; Venn et al., 2008), the long-term effects of such treatment are now being recognized. Today, it is known that high-dose estrogen therapy appears to reduce fertility later in life (Venn A, 2005), increase the risk for deep vein thrombosis (Weimann and Brack, 1996), as well as, possibly, increase the risk for breast and gynecological cancers (Genazzani et al., 2001). In contrast, treatment of idiopathic short stature by blocking estrogen biosynthesis successfully delays skeletal maturation and enhances adult height without serious side-effects (Hero et al., 2005). However, a recent investigation on pre-pubertal boys treated for six months with an AI to enhance their final height revealed that the elevated bone resorption caused by this drug was not paralleled by an increase in bone formation (Hero et al., 2009). Moreover, there is a strong correlation between serum levels of estradiol and BMD in males (Slemenda et al., 1997), once again emphasizing the importance of this sex hormone for bone health in both sexes.

1.3.4.7 ER α - and ER β -knockout strains of mice

To gain further insight into the role played by each individual ER, mouse strains deficient in ER α (ERKO), ER β (BERKO) or both (DERKO) have been generated (Lubahn et al., 1993; Krege et al., 1998; Dupont et al., 2000). ERKO mice generated in the laboratory of Dr. Smithies (Vidal et al., 1999; Windahl et al., 1999; Vidal et al., 2000; Lindberg et al., 2001; Windahl et al., 2001; Chagin et al., 2004) express a truncated form of ER α produced by alternative splicing (Pendaries et al., 2002) which contains the DBD and AF-2 domains, whereas, BERKO mice generated in this laboratory express no ER β at all. An ERKO mouse strain generated in the laboratory of Dr. Chambon (Sims et al., 2002; Tozum et al., 2004) is considered to be ER α -null, with no ER activity; whereas the, BERKO mice from the same group express isoforms of ER β .

The adult or elderly femur length of female ERKO mice is either normal (Sims et al., 2002; Tozum et al., 2004) or reduced (Lindberg et al., 2001; Parikka et al., 2005). Male ERKO mice exhibit inhibition of bone growth, both as adults (Vidal et al., 2000) and upon aging (Parikka et al., 2005), whereas knocking-out ER β does not influence bone growth in male mice at any stage of their development (Windahl et al., 1999; Vidal et al., 2000; Windahl et al., 2001; Sims et al., 2002). In contrast, the

corresponding knock-out in female mice stimulates adult bone length (Windahl et al., 1999; Lindberg et al., 2001; Chagin et al., 2004). With the double knock-out (DERKO), male mice exhibit growth inhibition to the same extent as the ERKO strain (Vidal et al., 2000), while female animals have longer bones than in the case of ERKO (Lindberg et al., 2001; Chagin et al., 2004). These observations suggest that ER β is involved in inhibition of longitudinal bone growth. The serum level of estradiol in female ERKO mice is higher than WT, BERKO or DERKO females (Lindberg et al., 2001). The differences between the phenotypes of the unique clinical case lacking ER α function mutation and the knock-out mice models might reflect species differences in the functions of other isoforms of ER. Moreover, the diverse phenotypes of male and female ER-knockout mice indicate the existence of sex-related functions of ERs in response to estrogen.

1.3.4.8 *Direct effects of estrogens on chondrocytes*

Indeed, the expression of ER α (Kusec et al., 1998), ER β (Nilsson et al., 1999) and GPR30 (Chagin and Sävendahl, 2007) by human epiphyseal chondrocytes supports direct actions of estrogens on these cells. However, at physiological levels estradiol does not influence cell proliferation and viability, synthesis of type X collagen, alkaline phosphatase activity, or matrix calcification in primary cultures of resting, proliferating, and prehypertrophic chondrocytes derived from the bovine fetal epiphyseal growth plate (Rodd et al., 2004). Similarly, we observed no significant effect of estradiol (10^{-8} - 10^{-5} M) on the proliferation of or matrix production by rat calvarias chondrocytes (the RCJ3.1C5.18 cell line) (Unpublished data, Karimian et al. 2005). Moreover, *in vitro* estradiol treatment of fetal (Chagin et al., 2006) and postnatal metatarsal bones from male and female rats does not influence longitudinal bone growth significantly (Unpublished data, Karimian et al. 2008). The effect of estrogens on longitudinal bone growth *in vivo*, but not *in vitro* suggests the presence of a cofactor *in vivo* which is lacking in cultures or, alternatively, that local production of estrogen in cultures masks the effects of exogenous estrogens (Chagin et al., 2006).

1.3.5 **Selective estrogen receptor modulators (SERMs)**

Because they act as selective estrogen agonists, certain SERMs can be used to prevent or treat diseases caused by estrogen deficiency, such as osteoporosis, without most of the undesirable side-effects of estrogens. Conversely, other SERMs act as selective estrogen antagonists and can therefore be used to prevent or treat

diseases, such as breast cancer, in which estrogen activity in a particular tissue is undesirable.

Thus, unlike estrogens, which are all agonists, and antiestrogens, which are all antagonists, SERMs include a diversity of compounds that can act as either ER agonists or antagonists in a tissue-specific manner (Cho and Nuttall, 2001). This pharmacological specificity allows dissociation of desirable estrogenic effects on the bone from undesirable stimulatory effects on the breast and endometrium. These compounds all lack the steroid structure of estrogens, but possess a tertiary structure that allows them to bind to the ERs. Most, but probably not all of their agonistic and antagonistic activities on target tissues for estrogens can be explained by three major interacting factors: differences in the levels of ER α and ER β expression, differences in the conformational changes that occur in ER upon ligand binding and differences in the expression of coregulator proteins (coactivators or corepressors) (Riggs and Hartmann, 2003).

PhytoSERMs are plant products that have been demonstrated scientifically to exert similar actions. Like other SERMs, these compounds act on the ERs in a selective manner, either as agonists or antagonists, thereby offering the possibility of selectively stimulating or inhibiting estrogen-like responses in different tissues. At present, two main and well-characterized classes of chemical SERMs have been approved for clinical use, whereas phytoSERMs are still under investigation.

1.3.5.1 Tamoxifen: a first generation SERM

Initially developed as an oral contraceptive, tamoxifen was actually found to induce ovulation in sub-fertile women and subsequently marketed for this purpose instead. In the early 1970's, following promising preliminary results in post-menopausal patients with breast cancer (Cole et al., 1971), this drug was reclassified as an anti-cancer agent and is now the most widely used adjuvant therapy in the treatment of breast cancer.

Although experience of its use with children has been limited, because of its anti-estrogenic properties tamoxifen was tested as a treatment for pubertal gynecomastia in adolescent boys (Derman et al., 2003; Lawrence et al., 2004) and precocious puberty in patients with McCune-Albright Syndrome (Eugster et al., 2003). In these studies longitudinal growth was either unaffected or diminished following months of treatment (Derman et al., 2003; Eugster et al., 2003; Lawrence et al., 2004). Differences in skeletal growth in response to tamoxifen treatment might reflect the use of heterogeneous groups of patients of different ages and stages of sexual maturation.

In gonadoectomized male and female rats tamoxifen causes a narrowing of the growth plate (Li et al., 1996; Fitts et al., 2004) and the final height attained and long-term safety of tamoxifen administration to young individuals is presently under investigation.

1.3.5.2 *Raloxifene: a second generation SERM*

Raloxifene acts as an estrogen agonist with regards to bone density and as an estrogen antagonist in breast and uterine tissues (Barrett-Connor, 2001) and, moreover, exert beneficial effects on postmenopausal osteoporosis (Cho and Nuttall, 2001). In rats, this compound inhibits longitudinal bone growth (Evans et al., 1994) while in ovariectomized rabbits it acts as an estrogen agonist on the growth plate accelerating chondrocyte senescence and thereby hastening epiphyseal fusion (Nilsson et al., 2003b). However, Zirilli and his colleagues (Zirilli et al., 2009) recently reported that, unlike in rats and rabbits, raloxifene do not accelerate epiphyseal fusion, but does enhance BMD and circulating levels of gonadotropins in aromatase-deficient humans. This lack of efficacy of raloxifene on growth plate ossification and mineralization in aromatase deficient humans may reflect their low serum concentrations of the drug, although there may also be species differences in this connection.

1.3.5.3 *Resveratrol: a phytoSERM*

The existence of phytoestrogens (plant compounds with estrogenic activity) has been known for more than 75 years (Bradbury and White, 1954). Despite their possible role as endocrine disrupters, in the past few decades phytoestrogens have become widely regarded as beneficial to human health, because of observations that populations whose diets contain high levels of such compounds have lower rates of certain estrogen-mediated conditions, such as cardiac disease, breast cancer, osteoporosis, and menopausal symptoms.

trans-resveratrol, a polyphenolic compound, is produced in response to stress, injury and infection by a variety of plants, including peanuts, berries, red grapes where it is located in the skin and the Asian cane *polygonum cuspidatum*. Its structural similarity to the potent synthetic estrogen diethylstilbestrol suggested that *trans*-resveratrol might be estrogenic, and, indeed, Gehm and coworkers (Gehm et al., 1997) demonstrated that this compound can compete with labeled E2 for receptor binding, activate the expression of estrogen-regulated genes, and stimulate the growth of estrogen-dependent breast cancer cells. However the affinity of its binding to the ER is rather low (Bowers et al., 2000).

It competes with E2 for binding to ER in an extract from MCF-7 human breast cancer cells with an IC50 value of approximately 10 μM (Gehm et al., 1997) and, furthermore, binds to rat uterine ER with an IC50 value of 100 μM (Ashby et al., 1999).

Interestingly, it has been reported that resveratrol is able to show anti-estrogenic effects via inhibition of aromatase P450, CYP19, enzyme in breast cancer cells *in vitro* (Wang et al., 2006). This compound inhibited aromatase activity with an IC50 value of 25 μM (Wang et al., 2006).

However, it should be pointed out that when administered orally, resveratrol has low bioavailability (Bhat et al., 2001a; Crowell et al., 2004; Baur and Sinclair, 2006) and, therefore, relatively high doses must be administered in order to achieve such serum concentrations. At present, pharmacological doses of resveratrol should be avoided since this compound can cause life-threatening symptoms, including kidney damage (Crowell et al., 2004), at least in rats.

In growing rats resveratrol exhibits little or no agonistic estrogen influence on reproductive and non-reproductive tissues that are targets for estrogen and may, indeed, act as an estrogen antagonist (Turner et al., 1999). At the same time, it is well known that resveratrol displays numerous mechanisms of biological action, targeting a great number of pathways not involving estrogen receptors (Shakibaei et al., 2009).

2 AIMS

The general aim of the present project was to characterize different selective estrogen receptor modulators (SERMs) with regards to their effects on growth plate cartilage and bone growth.

Specific Aims

1. To examine the effect of tamoxifen on longitudinal bone growth in cultures of fetal rat metatarsal bones.
2. To determine the *in vivo* effect of tamoxifen on bone growth in male rats.
3. To characterize the influence of resveratrol on longitudinal bone growth both *in vitro* and *in vivo*.
4. To establish cultures of postnatal rat metatarsal bones that enable studies of longitudinal bone growth.

3 METHODOLOGICAL CONSIDERATIONS

3.1 MODEL SYSTEM

3.1.1 A cell line (Paper I)

The well characterized HCS-2/8 cell line was originally established from a human chondrosarcoma by Takigawa and his colleagues (Takigawa et al., 1989). To date, this is the only human chondrocytic cell line with *in vivo*-like phenotypes with respect to cartilage such as the ability to synthesize cartilage-specific proteoglycans and type II collagen. These cells proliferate with a doubling time of 3-4 days and after more than 3 weeks in culture, they form three-dimensional nodules.

3.1.2 Organ culture of metatarsal bones (Papers I, III and IV)

3.1.2.1 Fetal rat metatarsal bones

Such organ cultures facilitate the study of the direct effects of various compounds including SERMs, in the absence of systemic factors. The unique feature of this model is that, as in the *in vivo* situation, chondrocytes in different phases of chondrogenesis are surrounded by cartilage matrix and have direct contact with each other, something which is absent in cell lines in culture.

Briefly, rudiments of metatarsal bones were collected from rat embryos at 20 days of gestation (De Luca et al., 2001). The three middle metatarsals were dissected from the hind paw and, after removing soft tissues, transferred to 24-well plates, where they were cultured in 1 ml of phenol red-free DMEM/F12 medium supplemented with 0.2% BSA (endotoxin –free fraction V), 1 mM β -glycerophosphate, 0.05 mg ascorbic acid per ml and 20 μ g gentamicin per ml at 37° C under a humidified atmosphere containing 5% CO₂. The medium was changed every 2-3 days and bone length measured on the first day (designated as day zero) and 2, 5, 7, and 12 days later and thereafter, once every week until the end of the experiment. This model was employed in Papers I, III and IV included in this thesis.

3.1.2.2 Postnatal rat metatarsal bones

It was of important to determine appropriate culturing conditions for postnatal bone growth *in vitro*, since such growth during fetal and postnatal life is regulated differently, at least in human. In this way, results obtained with this model might be more easily extrapolated to postnatal bone growth *in vivo*. A more detailed description of this model system is presented below in connection with the Results and Discussion concerning Paper IV.

3.1.3 Male Sprague-Dawley rats (Paper II)

Clearly, the regulation of longitudinal bone growth in rodents and humans differs. For instance, the pubertal growth spurt in humans occurs prior to epiphyseal fusion, whereas in rats and mice no acceleration of growth or epiphyseal fusion occurs except very late in life, when the epiphyses of some, but not all growth plates fuse.

Naturally, it is of importance to employ a model system for bone growth that is as similar as possible to the situation in humans when testing an estrogenic compound. We chose young male rats as the most suitable model for our study for the following reasons: rats metabolize tamoxifen administered orally in a manner similar to humans, whereas the metabolism of this drug by mice is quite different (Kisanga et al., 2003). The rats were used at four weeks of age which is considered to be pre-pubertal. Female rats were not utilized, since after puberty their estrous cycle might confound the estrogenic activity of our compound. We could not choose rabbits, since the information available about the pharmacokinetics of tamoxifen, which allows identification of an appropriate dose, concerns rats and mice.

For this experiment, four-week-old male Sprague Dawley rats were divided randomly into four different experimental groups, one of which received peanut oil for 4 weeks (the control), the second and third tamoxifen (40 mg/kg/day) for one or 4 weeks, and the fourth group 17 β -estradiol (40 μ g/kg/day) for 4 weeks. After 4 weeks half of the animals in each group were sacrificed, while the remaining animals continued the study for another 14 weeks (see Figure 6).

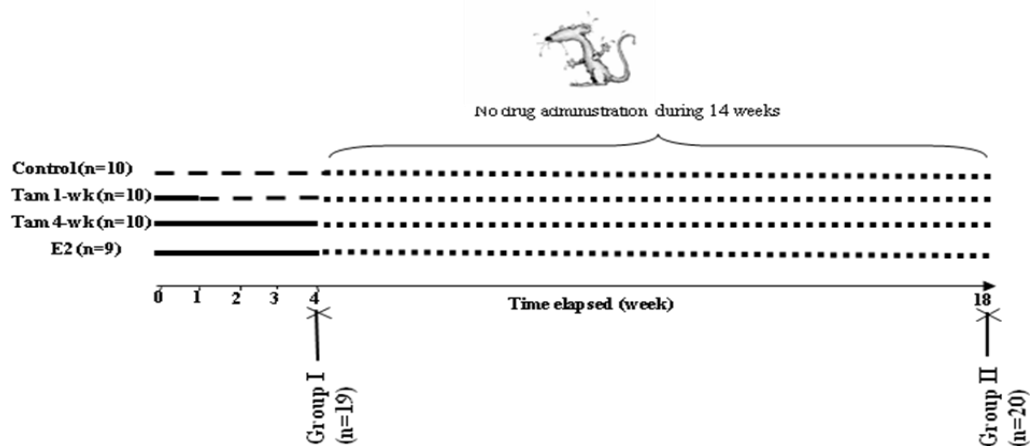

Figure 6: Schematic diagram illustrates the drugs and hormonal administration of tamoxifen (Tam) and estradiol (E2)

3.1.4 Ovariectomized New Zealand white rabbits (Paper III)

In this investigation we utilized rabbits, since in this animal, as in humans estrogen promotes chondrocyte senescence and accelerates fusion of the growth plate. Information concerning treatment of rabbits with E2 that produces nearly physiological serum level (Weise et al., 2001) is also available.

After being matched for body weight, sixteen-week-old ovariectomized rabbits were divided into 3 experimental groups: the control group received 7% ethanol/0.9% NaCl once daily by gavage, the resveratrol group 200 mg of this compound per kg per day, dissolved in 7% ethanol/ 0.9% NaCl and administered by the same route; and the estradiol cypionate group 70 µg of this hormone per kg once weekly by i.m. injection. After 7 weeks of such treatment, all of the animals in the E2 group and 5 each in the control and RES groups were sacrificed and the remaining animals were treated for an additional 3 weeks. Throughout this study, all of the rabbits received a soy bean-free diet and tap-water *ad libitum* and were subjected to a 12-h light/dark cycle. Following sacrifice with a high dose of pentobarbital, blood and tissue samples were collected for subsequent analysis.

3.2 ANALYSES OF BONE GROWTH AND STRUCTURE

3.2.1 Dual X-ray absorptiometry (DXA) (Paper II)

The two X-ray beams with differing energy levels employed to study bone density in particular also provide information concerning body composition (when soft tissue absorption has been subtracted out). The BMD can be determined from the absorption of each beam by bone, which can also be used to evaluate bone length in the smaller animals (i.e., rats and mice). Femur length and bone mineral densities were evaluated with the Norland pDEXA Sabre and the SABRE RESEARCH software (Version 3.6; Norland Medical Systems, Fort Atkinson, WI) while the animals were anesthetized with isoflurane inhalation gas.

3.2.2 Radiographic imaging (Papers II and III)

X-ray is a non-invasive and rapid procedure commonly used to determine bone age in humans and growth rate in laboratory animals. Our animals were anesthetized by intramuscular injection of Ketamin (25 mg/kg) and Xylazine (5 mg/kg) and the bone fixed in a flat position with tape for optimal imaging. The bone was visualized at a distance of 1.0 m utilizing 50-kV and 8.0-mAs settings. (Papers II and III)

3.2.3 Peripheral quantitative computed tomography (pQCT) (Papers II and III)

Tomographic measurements were performed using the Stratec XCT Research M (software version 5.4B; Norland Medical Systems Inc.) adapted especially for examination of small bones. Cortical bone parameters, including the cortical volumetric BMD, the cortical cross-sectional area, the periosteal circumference, the endosteal circumference, the moment of resistance, and the cross-sectional moment of inertia, were determined in the mid-diaphyseal femur and tibia by such scanning. To evaluate trabecular volumetric BMD, metaphyseal pQCT scans of femurs and tibias were also performed. The trabecular region of bone was defined as the inner 45% of the total cross-sectional area and the inter-assay coefficients of variation for the pQCT measurements were less than 2%.

3.2.4 Testing Mechanical properties (Paper II)

The mechanical properties of the femur shafts were tested employing a three-point bending test. The press head bent the middle of the femur shaft at a constant rate of 0.155 mm/s until fracture occurred. Subsequently, mechanical parameters, including ultimate strength (maximal load in N) and the energy absorbed by the bone tissue, which represents structural toughness (area under the load deformation curve, $\text{Nm} \times 10^{-3}$), were calculated.

3.3 QUANTITATIVE HISTOLOGY OF THE GROWTH PLATE (PAPER II AND III)

Sections of the growth plate of distal femurs and/or proximal tibias obtained from *in vivo* studies were stained with Alcian blue/van Geison or Masson Trichrome and assessed using a light microscope connected to a digital camera and computer. All of the histomorphometrical parameters in the central two-thirds of each stained section were evaluated by an observer who did not know the source of the section. The height of the growth plate, numbers of proliferative and hypertrophic chondrocytes per column, ratio of proliferative chondrocytes to hypertrophic chondrocytes and size of the terminal hypertrophic chondrocytes were determined by analysis of digital images of the growth plate employing the MicroimageTM software version 4.0 (Olympus Optical Co., Hamburg, Germany). In this connection, chondrocytes larger than 7 μm were considered to be hypertrophic. All values presented are the means of at least 24 measurements on each individual growth plate.

3.4 MONITORING CELL PROLIFERATION

3.4.1 Labeling 5-bromo-2'-deoxyuridine (BrdU) (Papers I-IV)

In our animal studies, chondrocytes replicating their DNA were identified on the basis of immunohistochemical detection of BrdU-labeled cells (employing the cell proliferation kit from Amersham Biosciences, Buckinghamshire, UK). Each animal received an intraperitoneal injection of BrdU (50 mg/kg) 2 and 16 hours prior to sacrifice and the number of BrdU-positive cells/unit was defined as the proliferation rate in the growth plate. Metatarsal bones cultured *in vitro*, were incubated prior to fixation for 2.5 hours with BrdU-labeling reagent (at 1:200 dilution in MEM medium; Cell Proliferation Kit RPN20, Amersham Biosciences, Buckinghamshire, UK) at 37° C. Following fixation, decalcification and embedding in paraffin, 5- μ m-thick sections were prepared. In this case the BrdU incorporated was detected with an anti-BrdU monoclonal primary antibody and anti-mouse IgG secondary antibody conjugated with horse radish peroxidase (HRP), in accordance with the manufacture's protocol. In Paper I, we made the modifications of replacing the HRP-conjugated secondary antibody with a FITC-conjugated secondary antibody (green fluorescence) and counterstaining with DAPI (blue fluorescence).

3.4.2 The WST-1 cell viability assay (Paper I)

The reagent 4-[3-(4-iodophenyl)-2(4-nitrophenyl)-2H-5-tetrazolio]-1,3-benzene disulfonate (WST-1; Roche Diagnostics GmbH, Mannheim, Germany) allows convenient quantification of cell proliferation and viability, on the basis of cleavage of this tetrazolium salt by mitochondrial dehydrogenases in living cells. An increase in the number of viable cells is reflected in an increase in the overall level of this mitochondrial dehydrogenase activity. This assay was performed in accordance with the manufacturer's instructions. Thus, HCS-2/8 cells were cultured in 96-well plates and treated with various doses of tamoxifen in phenol red-free DMEM/F12 medium supplemented with 1% CTS. Following such treatment, the WST-1 reagent was added at a final dilution of 1:10 and the reaction mixture incubated for 1 h at 37° C before determining the absorbance at 450 nm.

3.5 DETECTION OF APOPTOSIS

3.5.1 The TUNEL procedures (Papers I-IV)

Terminal deoxynucleotidyl transferase (TdT)-mediated deoxy-UTP nick end-labeling is a method for labeling the terminal end of nucleic acids. The blunt ends of fragmented double-stranded DNA, which are considered to be a central feature of classic apoptosis. The TUNEL assay has been optimized for application to growth plate

tissue in our laboratory (Chagin et al., 2004). Incorporation of biotin-labeling nucleotides into the DNA of apoptotic cells, was assessed either with DAB or with streptavidin conjugated to Alexa Fluor® 546 (Invitrogen Inc.) and the number of positive cells/unit area determined. Subsequently, the slides were embedded in DAPI-containing mounting medium (Vector Laboratories Inc.), and apoptotic chondrocytes detected as Alexa-546 positive cells (red fluorescence).

3.5.2 Cell death ELISA (Paper I)

The ELISA kit for detection of cell death allows the quantitative detection of histone-associated DNA fragments in mono- and oligonucleosomes (another marker for apoptotic cells). The advantages of this kit include its ability to assay many samples in a single run and its sensitivity and reproducibility in detecting apoptotic nucleosomes in cell lysates and tissue homogenates, while requiring fewer cells than other procedures. However, this method cannot distinguish apoptosis from necrosis.

3.5.3 Double-labeling with Annexin-V and propidium iodide (Paper I)

Apoptosis and necrosis are the two main modes of cell death. In apoptotic cells the structure of the plasma membrane, is altered such that phosphatidylserine (PS) is exposed at the extracellular surface. At the onset of apoptosis, this phospholipid is translocated to this exposed position, where it serves as a recognition signal for phagocytes.

Annexins are a family of homologous proteins that bind phospholipids in the presence of calcium and are expressed ubiquitously. Following the redistribution of phosphatidylserine from the internal to the external membrane surface, Annexin V and its conjugates can interact strongly and specifically with this exposed phospholipid.

Since it was of interest to distinguish between necrotic and apoptotic cells, the samples were also stained with propidium iodide (PI), a fluorescent dye which inserts into double-stranded DNA, but cannot cross cell membranes. As a result, necrotic cells and cells in late stages of apoptosis, with disrupted membranes are stained selectively by PI.

3.5.4 Fluorometric assay for caspase activity (Paper I)

The caspases are synthesized as inactive precursors and later activated through proteolytic cleavage, by other caspases, a process of considerable importance in determining cell survival. We assayed the activities of the initiator caspases-8 and -9 and the executor caspase-3 employing the fluorogenic peptide substrates IETD, LEHD

and DEVD, respectively. These substrates are conjugated with 7-amino-4-methyl coumarin (AMC), which can be detected fluorometrically upon cleavage and release.

3.6 DETERMINATION OF LEVELS OF PROTEIN EXPRESSION

3.6.1 Immunohistochemistry (IHC) (Papers I-IV)

The procedures utilizing specific antibodies to identify, localize and to a certain extent, quantify protein in the cells of a tissue section is referred to as immunohistochemistry. We employed this approach to detect the expression of type X collagen, parathyroid hormone-related peptide (PTHrP), Vascular Endothelial Growth Factor (VEGF) and Insulin-Like growth factor-I (IGF-I). However, first we had to do some troubleshooting.

Sections of cartilage tissue, especially when obtained from *in vivo* studies are very difficult to work with since they can easily detach from the slides.

In our hands, the use of coated glass slides did not solve this problem, but by employing ordinary Superfrost +/+ glass slides and indirect heating during antigen retrieval, the outcome could be improved. In detail, these slides were placed carefully on the bottom of beakers filled with sodium citrate buffer PH6 at 85° C and heating at the same temperature continued in a water bath for 30 minutes. During the washing step we avoided using suction, the buffer was removed gently from the corner of the slide and the remainder of the moisture absorbed with a tissue.

In all cases antigen retrieval was achieved by heating in sodium citrate buffer and/or enzyme treatments. To prevent or at least minimize unspecific binding, the tissue sections were incubated with 3% serum prior to addition of the primary antibody, which can be polyclonal or monoclonal, with the latter generally exhibiting greater specificity. It is also important to have both a positive control, i.e., a section of a tissue that is known to express the protein in question, and a negative control, i.e., a tissue section known to lack such expression. If necessary, a negative control can also be obtained by pre-incubation of the primary antibody with the appropriate peptide, replacement of the primary antibody with non-immunized serum and/or omission of the primary antibody. The second and third of these approaches are less reliable. The detailed immunohistochemical protocols employed for each protein are described in the Method and Methods section of the individual papers.

3.6.2 Western immunoblotting (Paper I)

This approach, also known as protein immunoblot, is utilized to detect and achieve relative quantitation of specific proteins in a tissue homogenate or cell extract. We applied this technique to quantify the levels of expression of caspase-3, -8

and -9, PARP, FasL, Bcl-xL, Bcl-xS and Bid by HCS-2/8 cells following treatment with tamoxifen. In each case an equal amount of protein was loaded (based on quantitation with a protein assay kit and confirmed by Coomassie Blue staining after the immunoblotting). The molecular weights of the bands obtained were determined by comparison to commercially available protein standards.

3.7 HIGH-PERFORMANCE LIQUID CHROMATOGRAPHY-TANDEM MASS SPECTROMETRY (LC-MS-MS) (PAPER II)

LC-MS-MS allows rapid, selective, sensitive and reliable quantification of tamoxifen and its metabolites, 4OHTam, NDtam, NDDtam, tamNox, and 4OHNDtam. In brief, serum samples from both the animals administered tamoxifen and control animals were obtained by allowing blood to clot at room temperature for 30 min, prior to centrifugation, and transfer of the serum supernatant to plastic vials. Serum proteins were removed by precipitation with acetonitrile prior to application of LC-MS-MS. In the case of cartilage the samples were first cut into small pieces, disrupted in ice-cold, 50 mM Tris-Cl, pH 7.4, with an ultrasonic homogenizer and centrifuged prior to assaying the resulting supernatant in the same manner. Deuterated-tamoxifen (D5tam) was added as an internal standard to all samples (Gjerde et al., 2005).

4 RESULTS AND DISCUSSION

4.1 TAMOXIFEN INHIBITS LONGITUDINAL BONE GROWTH PERMANENTLY *IN VITRO* (PAPER I)

Although tamoxifen, a first generation SERM, is already used to treat precocious puberty in patients with McCune Albright syndrome and boys with pubertal gynecomastia, the consequence of such treatment for growth has been controversial. Therefore, we employed the human chondrocytic cell line HCS-2/8 and fetal rat metatarsal bones to examine whether tamoxifen can directly affect chondrocytes and, as a result, longitudinal bone growth.

Tamoxifen retarded the growth of fetal rat metatarsal bones in a dose-dependent fashion, with even short-term treatment (5 days) abolishing growth completely. The TUNEL assay revealed that apoptotic cell death in these cultured metatarsal bones was limited to the resting and hypertrophic zones. Moreover, assay of cell proliferation with BrdU showed a dramatic reduction in the rate of this process, especially among chondrocytes in the resting zone. Tamoxifen also induced a time- and dose-dependent enhancement of apoptosis in the HCS-2/8 cell lines, a process mediated by activation of caspases. Moreover, tamoxifen stimulated the release of FasL from this chondrocytic cell line, which in turn activates Fas-mediated apoptosis.

The lowest dose of tamoxifen tested here, which is close to the serum concentration in patients treated with this drug (Robinson et al., 1991), resulted in permanent growth inhibition. The growth rate of patients with pubertal gynecomastia and McCune Albright syndrome is attenuated by tamoxifen (Eugster et al., 2003; Lawrence et al., 2004) while in boys with short stature tamoxifen decreases the rate of skeletal maturation and enhances the predicted adult height (Kreher et al., 2005). The discrepancy between these studies might reflect the use of heterogeneous groups of patients of different ages and stages of sexual maturation. Furthermore, in gonadectomized rats, but not those with intact gonads tamoxifen causes growth retardation (Li et al., 1996; Fitts et al., 2004; Perry et al., 2005), whereas in female mice, on the other hand, the same drug has been reported to stimulate bone growth (Perry et al., 2005). It is important to emphasize that all of these animal experiments were performed with serum concentrations of tamoxifen that were much lower than those in patients treated with this drug, a fact which might explain, at least in part, the discrepancies in the findings by different groups. It is also necessary to keep in mind

that the metabolism of tamoxifen in mice differs significantly from that in rats and humans (Robinson et al., 1991; Kisanga et al., 2003).

In an attempt to elucidate the mechanism underlying growth retardation by tamoxifen, chondrocyte proliferation, apoptosis and differentiation in fetal rat metatarsal bones exposed to tamoxifen were assessed. This drug induced massive apoptosis in resting and hypertrophic chondrocytes (Fig 3 in Paper I), as well as a clear reduction in the rate of proliferation among chondrocytes in the resting zone (Fig 3 in Paper I). Moreover, expression of type X collagen, a marker for differentiation, was significantly reduced. The late growth inhibitory effect of tamoxifen on fetal rat metatarsal bones also suggests that stem-like chondrocytes are eliminated and fewer cells thus recruited to the proliferative zone.

To further characterize the molecular mechanisms involved in triggering tamoxifen-induced apoptosis, activation of caspase-3, -8 and -9 was monitored. Activation of caspase-8 was detected after as little as 6 h of tamoxifen treatment, whereas activation of caspase-9 occurred after 12 h. This early activation of caspase-8 in chondrocytes indicates that tamoxifen-induced apoptosis involves the Fas/FasL pathway. We also made the novel finding that tamoxifen induced FasL release from the chondrocytes, which in turn would be expected to activate Fas-mediated apoptosis. Our findings here are supported by the reports that similar concentrations of tamoxifen induce activation of the Fas-pathway in osteoclasts (Wu et al., 2005) and glioma cells (Moodbidri and Shirsat, 2005) as well.

Indeed, the inhibitory effect of tamoxifen on the elongation of fetal rat metatarsal bones in culture appears to be irreversible. However, we know that *in vivo* different factors and compensatory mechanisms are involved and thus further investigation is required to confirm our present *in vitro* findings.

4.2 TAMOXIFEN IMPAIRS BONE GROWTH IN GROWING RATS (PAPER II)

Our previous demonstration that tamoxifen permanently inhibits the growth of fetal rat metatarsal bones in culture raises concerns about potential long-lasting negative side-effects of tamoxifen on bone physiology and linear growth. Accordingly, four-week-old male Sprague-Dawley rats were gavaged daily with vehicle alone (peanut oil), tamoxifen (40 mg/kg/day for 1 or 4 weeks) or estradiol (40 µg/kg/day for 4 weeks). After 4 weeks of this regimen, five of the 10 rats in each group were sacrificed and the other five allowed to recover for 14 weeks. Bone growth was

monitored by repeated DXA scans, while other bone parameters and spine length were evaluated by pQCT and X-ray at the time of sacrifice.

This four-week treatment of male rats with tamoxifen significantly reduced their body weight, nose-anus distance, spinal and tibial bone lengths, height of the growth plates, mineral density of trabecular bone, circumference of the cortical periosteum, and bone strength, as well as decreasing serum levels of IGF-I. Analysis of the tibial growth plate of the treated rats revealed enhanced chondrocyte proliferation (BrdU) and apoptosis (TUNEL), along with reductions in the number of hypertrophic chondrocytes and in the size of terminal hypertrophic chondrocytes. Despite complete restoration of body weight after 14 weeks of recovery, the tibia was still shorter ($p < 0.001$) and its cortical region smaller.

The motivation for using rats in this investigation was that these animals metabolize tamoxifen in a manner similar to humans (Kisanga et al., 2003), although only after oral administration (Kisanga et al., 2003). The metabolism of this drug by mice is quite different, which may explain the striking difference between the present responses of our rats to tamoxifen and the stimulatory effect of this drug on bone growth observed in mice (Perry et al., 2005). We attempted to achieve serum concentrations of tamoxifen and its metabolites similar to those in patients receiving this drug. When tamoxifen has been used to treat boys with pubertal gynecomastia or to limit estrogenic action in patients with McCune-Albright Syndrome, the doses administered have ranged between 20-40 mg/day (Ferlini et al., 1999; Eugster et al., 2003) and such doses have been reported to result in serum concentrations of 10-150 ng/ml (Lien et al., 1991). Here, the mean serum level of tamoxifen in our treated rats (25ng/ml) was thus comparable to the lowest concentrations observed in such patients. Moreover, the serum concentrations of tamoxifen metabolites detected here were similar to the lowest levels observed in patients treated with tamoxifen (Robinson et al., 1991).

In this investigation we demonstrated for the first time that tamoxifen reduces the height of the growth plate (Fig 5A and 5B in Paper II) and thereby attenuates axial and appendicular bone growth in young SD rats (Fig 7A and 7B). In line with these findings are those of the recent pilot study by Kreher and colleagues (Kreher, 2009) who treated growth hormone-deficient patients with tamoxifen in attempt to enhance predicted adult height. After one year of treatment, the predicted adult height was less than for the control group, although this difference was not statistically significant because of the small number of patients involved.

We also observed a decrease in food intake, followed by reductions in body weight and serum levels of IGF-I in tamoxifen-treated rats, suggesting that the retardation of bone growth may occur systemically via the GH/IGF-I axis. However, the elevation in apoptotic cell death (Fig 5K and 5L in Paper II) at the level of the growth plate, as well as the accumulation of tamoxifen and its active metabolites in the growth plate indicate that local inhibition of longitudinal bone growth is involved as well. In support of this conclusion, we showed that even after 14 weeks of recovery, when body weight and serum IGF-I had returned to control levels, spinal, and femur lengths were still shorter and cortical bone size reduced in the treated animals.

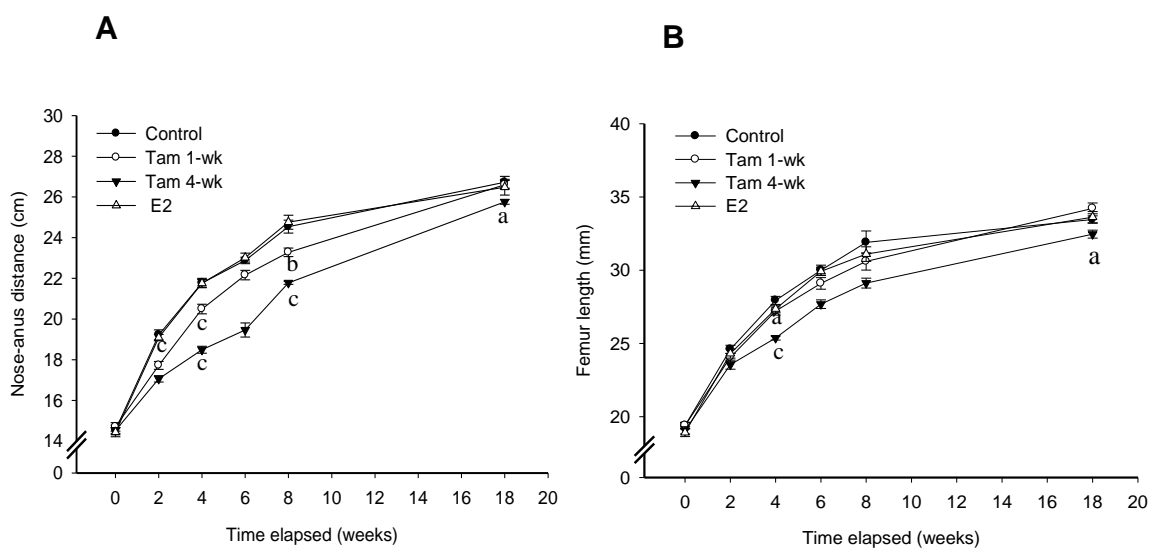

Figure 7. Nose-anus distance (A) and femur length (B) in rats treated with the vehicle alone (peanut oil=Control); tamoxifen (40 mg/kg/day) for 1 week followed by vehicle for 3 weeks (Tam 1-wk); the same dose of tamoxifen for 4 weeks (Tam 4-wk); or 17 β -estradiol (E2; 40 μ g/kg/day) for 4 weeks and thereafter allowed to recover for 14 weeks. The values shown are means \pm SE (n = 9-10 for the first 4 weeks and n=5 thereafter). ^ap<0.05, ^bp<0.01, ^cp<0.001 as compared to the control values. Difference between control and treated groups were evaluated by one-way ANOVA followed by Holm-Sidak post test.

However, in contrast to our previous findings on cultured metatarsal bones (Chagin et al., 2007), we observed here a partial “catch-up” of longitudinal bone growth following 14 weeks of recovery by animals treated previously with tamoxifen, a phenomenon associated with enhanced chondrocyte proliferation (Fig 7A and 7B). The occurrence of catch-up growth following exposure to tamoxifen *in vivo*, but not *in vitro* suggests compensatory up-regulation of systemic factors that promote longitudinal bone growth in the intact animal. However, catch-up growth of cortical bone does not occur, even after short-term (1-week) treatment with tamoxifen, indicating that bone is more susceptible than growth plate cartilage to the inhibitory effects of this drug.

We propose that in our model system tamoxifen blocks ER α -mediated actions in the bone, since the phenotype of our treated rats is very similar to that of male knock-out mice lacking ER α (Vidal et al., 2000), which also exhibit reduced serum levels of IGF-I (Vidal et al., 2000). However, we found earlier that tamoxifen induces apoptosis in a human chondrocytic cell line via non-genomic mechanisms and, moreover, that the non-selective ER antagonist ICI 182,780 was not able to prevent this process (Paper I). Here, we further confirm that tamoxifen enhances chondrocyte apoptosis, indicating that its skeletal effects involve both genomic and non-genomic mechanisms.

In conclusion, tamoxifen inhibits longitudinal bone growth in young male rats, an effect associated with elevated chondrocyte apoptosis, narrowing of the tibial growth plate and a reduction in the serum level of IGF-I. We also report here that tamoxifen causes a persistent reduction in cortical bone size as a result of attenuated periosteal and endosteal growth of the cortical bone. These findings suggest that if administered to growing children, tamoxifen may diminish their growth potential as well as increasing their risk for bone fractures.

4.3 RESVERATROL DELAYS GROWTH PLATE FUSION AND IMPROVE BONE GROWTH IN RABBITS (PAPER III)

The effect of *trans*-resveratrol (3, 5, 4'-trihydroxystilbene), a phytoSERM, on longitudinal bone growth were studied both in cultures of fetal rat metatarsal bones and in ovariectomized rabbits. Sixteen-week-old ovariectomized New Zealand white rabbits were divided by weight and matched into three groups: The control group was gavaged daily with 7% ethanol in 0.9% NaCl; The resveratrol received this drug (200 mg/kg) in the same vehicle by the same route; and the estrogen group received intramuscular injections of estradiol cypionate (70 μ g/kg/week) in sesame oil, all for 7 or 10 weeks. Axial and appendicular bone growth were monitored by X-ray once every two weeks while other bone parameters were evaluated by pQCT following sacrifice. Histomorphometrical analysis, measurement of the rate of cell proliferation, and immunohistochemical staining for VEGF were performed on paraffin-embedded sections prepared from the growth plate.

After 4 weeks of treatment, X-ray imaging revealed that all of the distal tibia growth plates were fused in all rabbits receiving E2, while 6% were open in the control group and 57% in the animals treated with resvertarol. After 7 weeks, the distal femur was open in all animals receiving resveratrol, whereas 90% and 60% of the animals in the control and E2 groups, respectively, still had an unfused growth plate at

this site. After 10 weeks, only 10% of control rabbits exhibited an open growth plate at this same site, while 33% of those receiving resveratrol still had an open growth plate. The proximal tibia, which was open at 7 weeks in all of the experimental groups, was closed in 50% of the control rabbits, but still open in all those treated with resveratrol after 10 weeks.

These observations were confirmed by histomorphometrical analysis of the growth plates. Analysis of sections stained with Masson-trichrome after 7 weeks revealed a significantly wider growth plate in resveratrol-treated than in control or estradiol-treated rabbits (Fig 8A, 8B and 8C). Furthermore, this enlargement of the growth plate was associated with a larger number of hypertrophic chondrocytes, a decreased rate of chondrocyte proliferation, and larger terminal hypertrophic cells. Expression of VEGF in the growth plate of resveratrol-treated rabbits was markedly suppressed. After 7 weeks of treatment, axial bone growth was accelerated by resveratrol and the spine length significantly exceeded that of control animals. After 10 weeks, the femur length in resveratrol-treated animals was also enhanced significantly ($p < 0.05$). As expected, treatment with E2 reduced the growth of the tibial bone and elevated cortical bone density. In contrast, trabecular and cortical bone densities were unaffected by resveratrol.

Studies in cultured fetal rat metatarsal bones verified a growth stimulatory effect of a low concentration of resveratrol (300 nM) confirming a local action of this drug in the growth plate.

Here, we document the novel finding that resveratrol stimulates growth plate cartilage, both *in vitro* and *in vivo*. In ovariectomized rabbits, this compound stimulated the growth of both axial and appendicular bone, without affecting the serum level of IGF-I. The treated rabbits had enlarged growth plates, an elevated number and size of hypertrophic chondrocytes, and a reduced both the rate of chondrocyte proliferation and the level of VEGF expression.

The dose of resveratrol employed here was chosen on the basis of the extremely low bioavailability of resveratrol (Bhat et al., 2001b; Crowell et al., 2004; Baur and Sinclair, 2006) in combination with available information concerning dosages in rodents (Bhat et al., 2001b; Crowell et al., 2004). In this investigation we demonstrate for the first time that resveratrol at the dose tested stimulates bone growth without affecting body weight or serum levels of IGF-I, suggesting local influence on the growth plate. However, despite enlarged growth plate and increases in the numbers and size of hypertrophic chondrocytes, the growth rate of long bones was not altered.

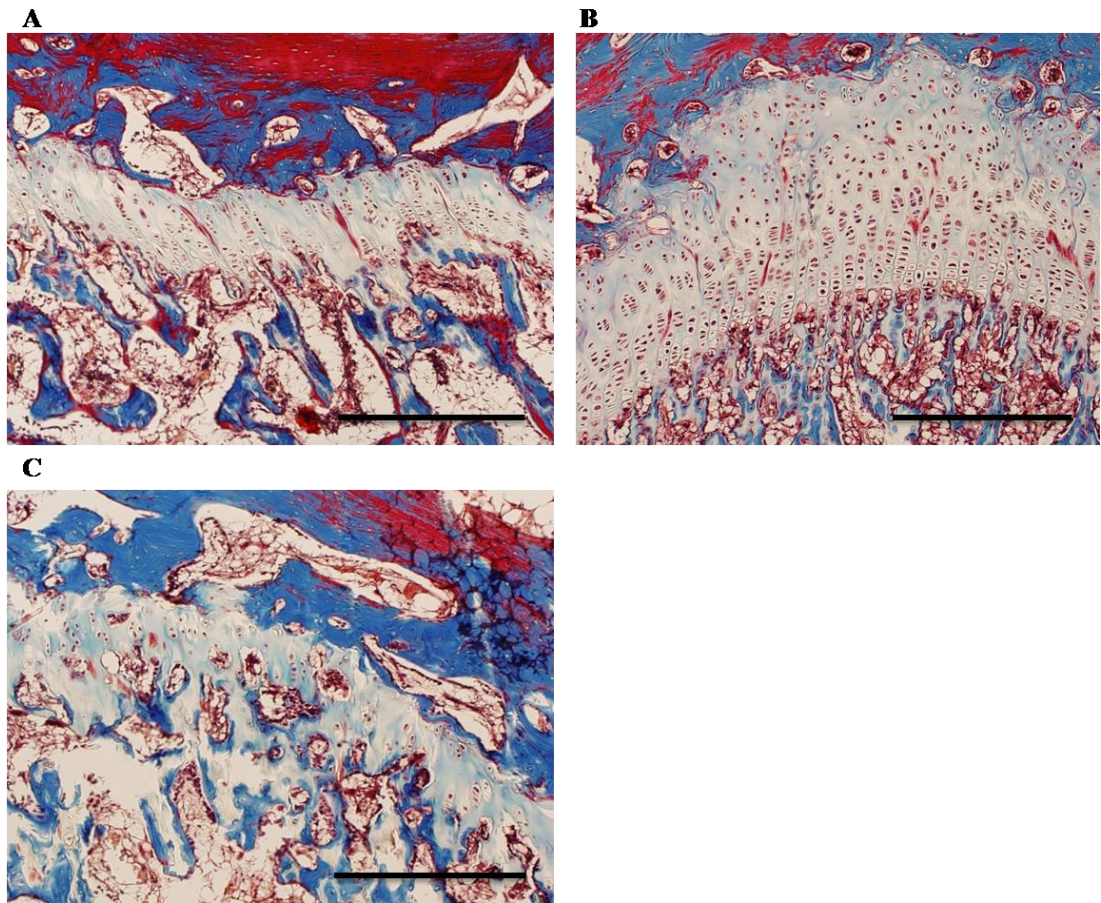

Figure 8: Representatives Masson-Trichrome-stained sections of the distal femur growth plate of control (A), resveratrol-treated (B) and estradiol-treated (C) rabbits. The bars represent a length of 500 μm .

To further elucidate the mechanism underlying the attenuation of chondrocyte proliferation in the rabbit growth plate by resveratrol (Fig 3A and 3B in Paper III), we determined the expression of VEGF, one of the important factors involved in endochondral ossification. It has been shown that systemic administration of a soluble VEGF receptor to young mice results in almost complete suppression of invasion of the growth plate by blood vessels, with concomitant impairment of trabecular bone formation and expansion of the zone of hypertrophic chondrocytes (Gerber et al., 1999). When paraffin-embedded sections of rabbit femur were examined immunohistochemically, VEGF, was seen to be expressed at high levels by hypertrophic chondrocytes, but only slightly in the resting and proliferative zones of control and E2-treated rabbits, and profoundly less in general in the resveratrol-treated animals (Fig 3D-3F in Paper III). This observation suggests that resveratrol may interfere with angiogenesis in the bone, which might explain how this compound affects both the morphology of the growth plate and bone growth.

In our opinion, the increase in femur length observed here would have been even more pronounced after longer periods of time, since after 10 weeks the distal femur growth plate was unfused in more of the resveratrol-treated animals. Although no significant effect on the rate of tibia growth by resveratrol was observed, there was a trend towards acceleration of this rate from week 7 until the end of the study period. This is in agreement with the fact that 100% of rabbits growth plates in resveratrol-treated animals, but only 60% of those in control rabbits remained unfused after 10 weeks.

Our findings strongly suggest that if the experiment had been prolonged, the resveratrol-treated animals would have developed longer bones, since at the end of our study period a reasonable number of the control animals had achieved their final height with fused growth plates and the rest exhibited narrower growth plates than the resveratrol group. Therefore, we propose that resveratrol can potentially improve bone elongation, at least in part, by partially inhibiting expression of VEGF in the growth plate.

4.4 CATCH-UP GROWTH OCCURS IN POSTNATAL RAT METATARSAL BONES CULTURED *IN VITRO* (PAPER IV)

These experiments were designed to determine appropriate conditions for culturing postnatal bones. Although cultures of fetal rat metatarsal bone provide a unique and well-established model system for studying longitudinal bone growth (De Luca et al., 2001) it is important to be cautious in interpreting the results obtained and making extrapolation to patients, since fetal and postnatal bones growth are regulated differently.

“Catch-up” growth refers to accelerated linear growth during recovery from growth inhibition. We developed a protocol for long-term culture of fetal (E20), as well as postnatal (P8) rat metatarsal bones that allowed us to characterize “catch-up” growth *in vitro* free from the influence of any systemic factors. Using this system we found that the growth of both E20 and P8 bones is stimulated by insulin-like growth factor-I (100 ng/ml) and inhibited by dexamethasone (Dexa; 1 μ M). However, following 7 or 12 days treatment with dexamethasone and a recovery period of 4-5 months, “catch-up” growth clearly occurred in P8, but not in E20 bones. At the same time, with a longer period of treatment (19 days) prior to 4 months of recovery, the length of both types of bone was compromised.

Dexamethasone is a well-known and extensively characterized inhibitor of growth. This compound exerts its inhibitory effect both systemically,

through down-regulation of the GH/IGF-I axis, and by direct inhibition of chondrocyte proliferation and mineralization and enhanced apoptosis (van der Eerden et al., 2003; Mushtaq et al., 2004; Nilsson et al., 2005). These direct effects are believed to be partially due to down-regulation of the GH receptor and/or the IGF-I receptor in the growth plate (van der Eerden et al., 2003; Nilsson et al., 2005).

The role played by dexamethasone in connection with “catch-up” growth is poorly understood. It was first proposed by Tanner in 1963 that “catch-up” growth represents an adjustment of the mismatch between actual and target size by accelerating growth rate through neuroendocrine mechanisms (Tanner and O’Keeffe, 1962). Three decades later, this proposal was challenged by the observation by Baron and his colleagues (Baron et al., 1992; Baron et al., 1994) that partial “catch-up” growth of only one leg of a rabbit occurred in response to local infusion of dexamethasone into the growth plate of that leg. However, the relative contributions of systemic and local processes during “catch-up” growth remained unclear, and there have been a need for an appropriate *in vitro* model to address this question.

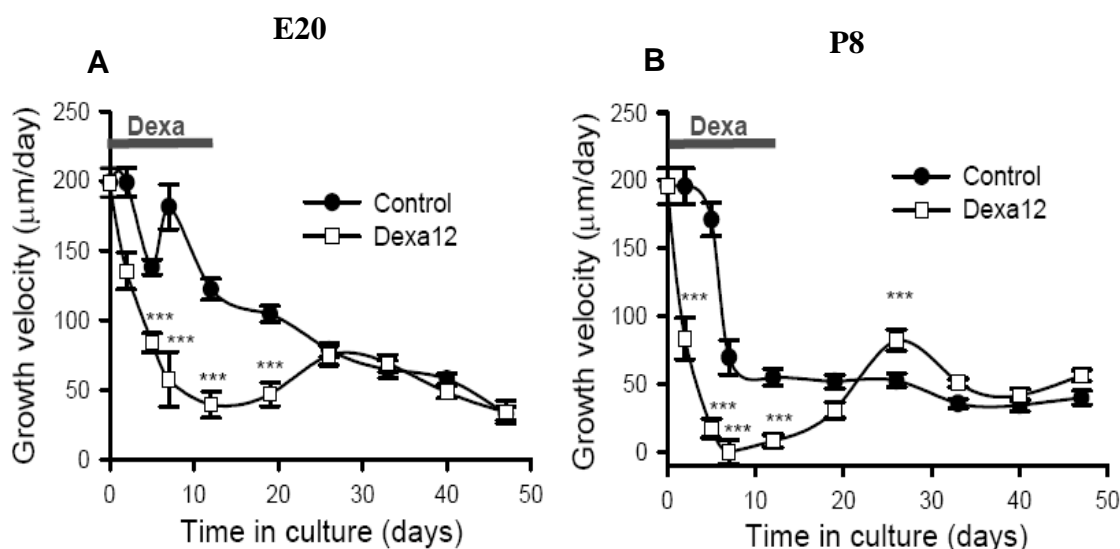

Figure 9. Metatarsal bones dissected from rat embryos on day 20 of gestation (E20) (A) or from 8-day-old rats (P8) (B) were cultured *ex vivo* in DMEM/F12 medium in the presence (□) or absence (●) of Dexa (Dexamethasone, 1 µM). Dexa was present in the treated cultures during the first 12 days (Dexa12), after which, the bones were washed with PBS and cultured without this compound. Growth velocity (A, B) was measured after 2, 5, 7, and 12 days in culture and, thereafter, once a week. Data represent means ± SE. ****p*<0.001 in comparison to the corresponding control value. The unpaired Student’s t-test was used to calculate statistical differences between two groups.

Here, we employed supplemented DMEM/F12 medium, which has proven to be superior to other media for organ culture in our laboratory (Mårtensson et al., 2004; Chagin et al., 2007; Heino et al., 2008). Under these serum-free conditions both E20 and P8 bones grow for as long as 5 months, in contrast to the previous belief

that postnatal bones do not grow *ex vivo* (Scheven and Hamilton, 1991; Coxam et al., 1996). In comparison to E20 bones, both the growth rate and chondrocyte proliferation of P8 bones declines more rapidly in culture. This difference might be referred to the fact that chondrocytes from P8 bones are more aged than E20 chondrocytes (the senescence hypothesis) (Baron et al., 1994) and thereby exhibit less capacity for proliferation. Interestingly, in our cultures the growth rate of these bones did not approach zero, confirming the suitability of our culture conditions. Surprisingly, even after being in culture for a long period, both types of bone still responded to stimulation by IGF-I.

Upon exposure to dexamethasone, the growth of P8 bones ceased almost completely, whereas the E20 bones continued to grow at a reduced rate (Fig 9A and 9B). In contrast, the P8 bones recovered more effectively than the fetal bones from 7 or 12 days of dexamethasone treatment. After two weeks of recovery, the growth rate of the former exceeded the control rate (Fig 9A and 9B) and after 5 months, these P8 bones had attained the same length as the control bones. However, following prolonged exposure to dexamethasone (19 days) the growth of P8 bones remained retarded even after months of recovery.

These findings are in agreement with clinical observations that short-term treatment of children with dexamethasone is followed by full “catch-up” growth, whereas prolonged exposure results in incomplete “catch-up” growth and compromised adult height (Mosier et al., 1972; Strickland et al., 1972). The key underlying mechanism for “catch-up” growth during 5 days of recovery in our model involved elevated cell proliferation. However, chondrocyte differentiation, which was attenuated by dexamethasone, did not return to normal during the recovery period.

Thus, in this investigation we showed for the first time, employing an *in vitro* model system, that “catch-up” growth following dexamethasone treatment is regulated locally at the growth plate. Interestingly, the local level of IGF-I, which was previously proposed to be the regulator of this “catch-up” growth (van der Eerden et al., 2003), played no significant role in our cultures.

5 CONCLUSIONS

The studies included in this thesis clearly show that SERMs influence growth plate cartilage, the growth of longitudinal bones and bone structures. First, the effects of tamoxifen, a well-known first generation SERM, on the growth of fetal rat metatarsal bones in culture was characterized. The massive apoptosis, specifically in stem-like resting chondrocytes in the growth plate cartilage, and permanent growth arrest observed motivated us to investigate the effects of this drug *in vivo*, using an appropriate animal model and proper dose.

Indeed, clinically relevant concentrations of tamoxifen persistently retarded the growth of longitudinal and cortical radial bones in young male rats. This inhibition involved both local effects on the growth plate and systemic suppression of serum levels of IGF-I.

Thereafter, we examined resveratrol a novel SERM, that due to its promising effects in animal models of different human diseases has been studied extensively in recent years. Interestingly, this compound exerted a biphasic effect on the growth of fetal rat metatarsal bones in culture, stimulating this growth at low concentrations and inhibiting at high concentrations. *In vivo*, the dose tested improved both axial and appendicular bone growth without altering serum levels of IGF-I, an effect that was associated with partial inhibition of the local expression of VEGF and delayed growth plate fusion.

Finally, we developed a system for culturing postnatal rat metatarsal bones that is valuable for studying bone growth. This model system will enable us to examine postnatal bone growth *in vitro* following exposure to SERMs, potentially aiding the development of future treatment strategies designed to ameliorate growth disorders.

6 ACKNOWLEDGEMENTS

The work presented in this thesis was carried out at the Pediatric Endocrinology Unit, Department of Women's and Children's Health, Karolinska Institutet, Stockholm. I wish to express my gratitude to everyone who helped me to run this project and finish this journey. My special thanks to:

My main supervisor, *Professor Lars Sävendahl*, for his valuable guidance, support and advice from the beginning until defense. You have provided such nice environment in the group and created a cooperative atmosphere. Thank you for giving me the opportunity of working with you and being a part of your research group. Lars, your way of supervision, teaching and work discipline is very educational and I hope what I have learned from you will make me a better researcher.

Dr. Andrei S Chagin, my co-supervisor and my lab mentor for teaching me different lab techniques and methods in a professional way. Despite of a relatively long distance in the last two years, you have still been actively involved in my projects and always happy to help and a very quick responder whenever I needed. Andrei, you are a good listener and a precious advisor, it has been a pleasure working with you.

My co-supervisor, *Professor Karin Dahlman-Wright*, for being a knowledgeable person.

Professor Martin Ritzen, for his valuable scientific comments during our group meetings at the very beginning of my study.

Professor Olle Soder, for creating an excellent scientific environment in the laboratory. Also thanks for managing lab-retreats, Christmas lunches and your generous invitation for Christmas glögg in your home every year.

Dr. Cecilia Camacho-Hubner, you brought a nice spirit to our group but unfortunately for us the time was short. Ceci, you are an excellent advisor in both work and life matters. Thank you for the excellent comments on the draft of my thesis and your always smiling face.

My Norwegian collaborators *Professor Ernst A Lien* and *Dr. Jennifer Gjerde* from University of Bergen for fruitful collaboration during Tamoxifen project.

My collaborator from Sahlgrenska University Hospital Gothenburg, *Professor Claes Ohlsson* for providing us bone analysis in his facilities and his helpful inputs and comments in my studies.

Associate Professor Lena Sahlin, for your generous help whenever I needed it and valuable advices during the resveratrol study.

I would like to express my sincere gratitude to senior scientists, my past and present friends/colleagues in Ritzen laboratory: *Lars Hagenes*, *Peter bang*, *Mikael Holst*,

Konstantin Svenchnikov, Irina Svenchnikova, Ola Nilsson, Aida Wahlgren, Christine Carlsson-Skwirut, Kirsi Jahnukainen, Mi Hou, Vichit Supornsilchai, Blesson C. Selvanesan, Taranum Soltana, Kerstin Sollerbrant, Jan-Bernd Stukenborg, Mona-Lisa Strand, Ulrika Berg, Nina Renlund, Sara Gustafsson, Maria Ahlsén, Momina Mirza, Lin Ma, Shahzad Akram, Therese Cederval and Maryana Hulchiy for making an enjoyable and friendly environment.

Britt Masironi for her good advice in immunohistochemistry and lending me whatever I needed during my experiments. *Susanne Hallberg* for her administrative help and interesting chats in coffee breaks.

Yvonne Löfgren, you have always surprised me with your back-ups!! Thanks a lot Yvone for your technical support and help during this period and for your valuable efforts to keep everything in order in the laboratory.

Ann-Christine Eklöf for good advice and technical support in my animal studies. Monica Aronsson, Kristina Edwardsson, Linda Söderlind and Wiveka Vanrillaer for technical supports and assistance during animal studies.

Ulf Hörnberg, for professional help with tissue sectioning and providing me the excellent sections, Mikael Reimeringer for his valuable help with computer issues and quick reply to solve the problems.

Eugenia Colon, my friend, thanks for the interesting chats and a very nice friendship. *Luise Landreh*, It has been joyful sitting next to you. Thank you for sharing funny jokes/news which always makes me happy and provides me a good break!

I wish to thank my friends and colleagues in the growth plate group:

Paola Fernandez-Vojvodich, for lots of fun, pleasant friendship and interesting common memories. It has been a pleasure knowing you and being the witness of your marriage.

Farasat Zaman, for interesting discussions about both science and life. Thank you for the scientific inputs, ideas and your generous practical help in the urgent moments during my study.

Emma E Eriksson, an easy going person and generous to help others. I like your patience in translation of complicated Swedish texts for me. ☺

Katja Sundstrum, a good advisor both in social activities and scientific aspects. I wish you success in your PhD project.

Terhi Heino, my Finnish friend, a well organized, in order and caring person. Your friendship is important to me. It has been fun sharing room with you both in Helsinki and New York. You are an excellent roommate and a good company while catching celebrities!!!

Chen Lui for being an excellent student and *Karin Samuelson* for a nice collaboration.

I wish to thank *my dear mother* for her endless and unconditional love, support and believing in me since early years. Thank you for being an incredible mother and generous in your love for me. *My great father*, thank you for your kindness, support and enthusiasm all through my study. Thanks for teaching me to think everything in depth in advance before taking the first step. My wish is to see both of you always healthy and happy. My dear brother, *Ahmad*, for your love, supports and frequent calls which always makes me happy. Thank you for being such a caring brother and I wish you always everything the best. My dear sister, *Vida* for your love, encourages and cares. It has been my good fortune to have you close to me. I have always admired your transparency and honesty. Also I would like to thank my other dear *sisters* and *brothers*, *Haydeh*, *Ali*, *Roya*, *Enayat* and *Fariba* for their kindness and love.

My father and *my mother in law*, thank you for being such lovely people; always helpful, extremely nice and kind.

I would like to thank the precious treasures of my life, my daughters *Aylin* and *Atrisa*. My dear *Aylin* for your understanding, mature way of thinking and your valuable efforts in school subjects that always make me and your father proud of you. My little *Atrisa* for making us happier and our lives more warm and shiny.

Above all, I would like to express my special appreciation to my best friend and the love of my life, *Shahram*. Despite not being involved in my study, your enthusiasm was encouraging me to discuss my work with you and your ideas have been always helpful. You are such an incredibly caring and supportive husband for me and the best father for our children. Thank you for believing in me and being with me in every moment of this journey, ups and downs. I am so grateful to share my life with you.

This work was supported by the Swedish Research Council, Sällskapet Barnavård, Stiftelsen Frimurare Barnhuset i Stockholm, Stiftelsen Samariten and HKH Kronprinsessan Lovisas förening för Barnasjukvård.

7 REFERENCES

- Abu EO, Horner A, Kusec V, Triffitt JT, Compston JE. 1997. The localization of androgen receptors in human bone. *J Clin Endocrinol Metab* 82(10):3493-3497.
- Abu EO, Horner A, Kusec V, Triffitt JT, Compston JE. 2000. The localization of the functional glucocorticoid receptor alpha in human bone. *J Clin Endocrinol Metab* 85(2):883-889.
- Aizawa T, Kokubun S, Tanaka Y. 1997. Apoptosis and proliferation of growth plate chondrocytes in rabbits. *J Bone Joint Surg Br* 79(3):483-486.
- Allen DB. 1996. Growth suppression by glucocorticoid therapy. *Endocrinol Metab Clin North Am* 25(3):699-717.
- Altman A, Hochberg Z, Silbermann M. 1992. Interactions between growth hormone and dexamethasone in skeletal growth and bone structure of the young mouse. *Calcif Tissue Int* 51(4):298-304.
- Ashby J, Tinwell H, Pennie W, Brooks AN, Lefevre PA, Beresford N, Sumpter JP. 1999. Partial and weak oestrogenicity of the red wine constituent resveratrol: consideration of its superagonist activity in MCF-7 cells and its suggested cardiovascular protective effects. *J Appl Toxicol* 19(1):39-45.
- Bacon AL, Harris AL. 2004. Hypoxia-inducible factors and hypoxic cell death in tumour physiology. *Ann Med* 36(7):530-539.
- Ballock RT, O'Keefe RJ. 2003. The biology of the growth plate. *J Bone Joint Surg Am* 85-A(4):715-726.
- Baron J, Huang Z, Oerter KE, Bacher JD, Cutler GB, Jr. 1992. Dexamethasone acts locally to inhibit longitudinal bone growth in rabbits. *Am J Physiol* 263(3 Pt 1):E489-492.
- Baron J, Klein KO, Colli MJ, Yanovski JA, Novosad JA, Bacher JD, Cutler GB, Jr. 1994. Catch-up growth after glucocorticoid excess: a mechanism intrinsic to the growth plate. *Endocrinology* 135(4):1367-1371.
- Barrett-Connor E. 2001. Raloxifene: risks and benefits. *Ann N Y Acad Sci* 949:295-303.
- Baur JA, Sinclair DA. 2006. Therapeutic potential of resveratrol: the in vivo evidence. *Nat Rev Drug Discov* 5(6):493-506.
- Baur ST, Mai JJ, Dymecki SM. 2000. Combinatorial signaling through BMP receptor IB and GDF5: shaping of the distal mouse limb and the genetics of distal limb diversity. *Development* 127(3):605-619.
- Ben-Ami Y, von der Mark K, Franzen A, de Bernard B, Lunazzi GC, Silbermann M. 1993. Transformation of fetal secondary cartilage into embryonic bone in organ cultures of human mandibular condyles. *Cell Tissue Res* 271(2):317-322.
- Ben-Hur H, Thole HH, Mashiah A, Insler V, Berman V, Shezen E, Elias D, Zuckerman A, Ornoy A. 1997. Estrogen, progesterone and testosterone receptors in human fetal cartilaginous tissue: immunohistochemical studies. *Calcif Tissue Int* 60(6):520-526.
- Bhat KP, Lantvit D, Christov K, Mehta RG, Moon RC, Pezzuto JM. 2001a. Estrogenic and antiestrogenic properties of resveratrol in mammary tumor models. *Cancer Res* 61(20):7456-7463.
- Bhat KPL, Kosmeder JW, 2nd, Pezzuto JM. 2001b. Biological effects of resveratrol. *Antioxid Redox Signal* 3(6):1041-1064.
- Boisclair YR, Rhoads RP, Ueki I, Wang J, Ooi GT. 2001. The acid-labile subunit (ALS) of the 150 kDa IGF-binding protein complex: an important but forgotten component of the circulating IGF system. *J Endocrinol* 170(1):63-70.
- Bowers JL, Tyulmenkov VV, Jernigan SC, Klinge CM. 2000. Resveratrol acts as a mixed agonist/antagonist for estrogen receptors alpha and beta. *Endocrinology* 141(10):3657-3667.
- Bradbury RB, White DE. 1954. Estrogens and related substances in plants. *Vitam Horm* 12:207-233.

- Bronckers AL, Goei W, Luo G, Karsenty G, D'Souza RN, Lyaruu DM, Burger EH. 1996. DNA fragmentation during bone formation in neonatal rodents assessed by transferase-mediated end labeling. *J Bone Miner Res* 11(9):1281-1291.
- Carani C, Qin K, Simoni M, Faustini-Fustini M, Serpente S, Boyd J, Korach KS, Simpson ER. 1997. Effect of testosterone and estradiol in a man with aromatase deficiency. *N Engl J Med* 337(2):91-95.
- Carel JC, Blumberg J, Bougourd-Julien M, Rochiccioli P, Chaussain JL, Tauber M. 2009. Long-acting lanreotide in adolescent girls with constitutional tall stature. *Horm Res* 71(4):228-236.
- Chagin AS, Chrysis D, Takigawa M, Ritzen EM, Savendahl L. 2006. Locally produced estrogen promotes fetal rat metatarsal bone growth; an effect mediated through increased chondrocyte proliferation and decreased apoptosis. *J Endocrinol* 188(2):193-203.
- Chagin AS, Karimian E, Zaman F, Takigawa M, Chrysis D, Savendahl L. 2007. Tamoxifen induces permanent growth arrest through selective induction of apoptosis in growth plate chondrocytes in cultured rat metatarsal bones. *Bone* 40(5):1415-1424.
- Chagin AS, Lindberg MK, Andersson N, Moverare S, Gustafsson JA, Savendahl L, Ohlsson C. 2004. Estrogen receptor-beta inhibits skeletal growth and has the capacity to mediate growth plate fusion in female mice. *J Bone Miner Res* 19(1):72-77.
- Chagin AS, Sävendahl L. 2007. GPR30 estrogen receptor expression in the growth plate declines as puberty progresses. *J Clin Endocrinol Metab* 92(12):4873-4877.
- Chagin AS, Vannesjo J, Sävendahl L. 2009. Androgen receptor modulation does not affect longitudinal growth of cultured fetal rat metatarsal bones. *Horm Res* 71(4):219-227.
- Cho CH, Nuttall ME. 2001. Therapeutic potential of oestrogen receptor ligands in development for osteoporosis. *Expert Opin Emerg Drugs* 6(1):137-154.
- Chrysis D, Ritzen EM, Savendahl L. 2003. Growth retardation induced by dexamethasone is associated with increased apoptosis of the growth plate chondrocytes. *J Endocrinol* 176(3):331-337.
- Cole MP, Jones CT, Todd ID. 1971. A new anti-oestrogenic agent in late breast cancer. An early clinical appraisal of ICI46474. *Br J Cancer* 25(2):270-275.
- Collett-Solberg PF, Misra M. 2008. The role of recombinant human insulin-like growth factor-I in treating children with short stature. *J Clin Endocrinol Metab* 93(1):10-18.
- Colvin JS, Bohne BA, Harding GW, McEwen DG, Ornitz DM. 1996. Skeletal overgrowth and deafness in mice lacking fibroblast growth factor receptor 3. *Nat Genet* 12(4):390-397.
- Coxam V, Miller MA, Bowman MB, Miller SC. 1996. Ontogenesis of IGF regulation of longitudinal bone growth in rat metatarsal rudiments cultured in serum-free medium. *Arch Physiol Biochem* 104(2):173-179.
- Crowell JA, Korytko PJ, Morrissey RL, Booth TD, Levine BS. 2004. Resveratrol-associated renal toxicity. *Toxicol Sci* 82(2):614-619.
- De Luca F, Barnes KM, Uyeda JA, De-Levi S, Abad V, Palese T, Mericq V, Baron J. 2001. Regulation of growth plate chondrogenesis by bone morphogenetic protein-2. *Endocrinology* 142(1):430-436.
- Derman O, Kanbur NO, Kutluk T. 2003. Tamoxifen treatment for pubertal gynecomastia. *Int J Adolesc Med Health* 15(4):359-363.
- Donohue MM, Demay MB. 2002. Rickets in VDR null mice is secondary to decreased apoptosis of hypertrophic chondrocytes. *Endocrinology* 143(9):3691-3694.
- Drop SL, De Waal WJ, De Muinck Keizer-Schrama SM. 1998. Sex steroid treatment of constitutionally tall stature. *Endocr Rev* 19(5):540-558.
- Dupont S, Krust A, Gansmuller A, Dierich A, Chambon P, Mark M. 2000. Effect of single and compound knockouts of estrogen receptors alpha (ERalpha) and beta (ERbeta) on mouse reproductive phenotypes. *Development* 127(19):4277-4291.
- Elias LL, Huebner A, Metherell LA, Canas A, Warne GL, Bitti ML, Cianfarani S, Clayton PE, Savage MO, Clark AJ. 2000. Tall stature in familial glucocorticoid deficiency. *Clin Endocrinol (Oxf)* 53(4):423-430.

- Emons J, Chagin AS, Hultenby K, Zhivotovsky B, Wit JM, Karperien M, Savendahl L. 2009. Epiphyseal fusion in the human growth plate does not involve classical apoptosis. *Pediatr Res* 66(6):654-659.
- Erenpreisa J, Roach HI. 1998. Aberrant death in dark chondrocytes of the avian growth plate. *Cell Death Differ* 5(1):60-66.
- Eugster EA, Rubin SD, Reiter EO, Plourde P, Jou HC, Pescovitz OH. 2003. Tamoxifen treatment for precocious puberty in McCune-Albright syndrome: a multicenter trial. *J Pediatr* 143(1):60-66.
- Evans G, Bryant HU, Magee D, Sato M, Turner RT. 1994. The effects of raloxifene on tibia histomorphometry in ovariectomized rats. *Endocrinology* 134(5):2283-2288.
- Farnum CE, Wilsman NJ. 1987. Morphologic stages of the terminal hypertrophic chondrocyte of growth plate cartilage. *Anat Rec* 219(3):221-232.
- Farnum CE, Wilsman NJ. 1989a. Cellular turnover at the chondro-osseous junction of growth plate cartilage: analysis by serial sections at the light microscopical level. *J Orthop Res* 7(5):654-666.
- Farnum CE, Wilsman NJ. 1989b. Condensation of hypertrophic chondrocytes at the chondro-osseous junction of growth plate cartilage in Yucatan swine: relationship to long bone growth. *Am J Anat* 186(4):346-358.
- Fell HB. 1932. The Osteogenic Capacity in vitro of Periosteum and Endosteum Isolated from the Limb Skeleton of Fowl Embryos and Young Chicks. *J Anat* 66(Pt 2):157-180 111.
- Ferlini C, Scambia G, Marone M, Distefano M, Gaggini C, Ferrandina G, Fattorossi A, Isola G, Benedetti Panici P, Mancuso S. 1999. Tamoxifen induces oxidative stress and apoptosis in oestrogen receptor-negative human cancer cell lines. *Br J Cancer* 79(2):257-263.
- Fitts JM, Klein RM, Powers CA. 2004. Comparison of tamoxifen and testosterone propionate in male rats: differential prevention of orchidectomy effects on sex organs, bone mass, growth, and the growth hormone-IGF-I axis. *J Androl* 25(4):523-534.
- Gehm BD, McAndrews JM, Chien PY, Jameson JL. 1997. Resveratrol, a polyphenolic compound found in grapes and wine, is an agonist for the estrogen receptor. *Proc Natl Acad Sci U S A* 94(25):14138-14143.
- Genazzani AR, Gadducci A, Gambacciani M. 2001. Controversial issues in climacteric medicine II. Hormone replacement therapy and cancer. *Maturitas* 40(2):117-130.
- Gerber HP, Hillan KJ, Ryan AM, Kowalski J, Keller GA, Rangell L, Wright BD, Radtke F, Aguet M, Ferrara N. 1999. VEGF is required for growth and survival in neonatal mice. *Development* 126(6):1149-1159.
- Gevers EF, van der Eerden BC, Karperien M, Raap AK, Robinson IC, Wit JM. 2002. Localization and regulation of the growth hormone receptor and growth hormone-binding protein in the rat growth plate. *J Bone Miner Res* 17(8):1408-1419.
- Giustina A, Mazziotti G, Canalis E. 2008. Growth hormone, insulin-like growth factors, and the skeleton. *Endocr Rev* 29(5):535-559.
- Gjerde J, Kisanga ER, Hauglid M, Holm PI, Mellgren G, Lien EA. 2005. Identification and quantification of tamoxifen and four metabolites in serum by liquid chromatography-tandem mass spectrometry. *J Chromatogr A* 1082(1):6-14.
- Goldzieher MA. 1956. Treatment of excessive growth in the adolescent female. *J Clin Endocrinol Metab* 16(2):249-252.
- Gottlicher M, Heck S, Herrlich P. 1998. Transcriptional cross-talk, the second mode of steroid hormone receptor action. *J Mol Med* 76(7):480-489.
- Green S, Walter P, Greene G, Krust A, Goffin C, Jensen E, Scrace G, Waterfield M, Chambon P. 1986. Cloning of the human oestrogen receptor cDNA. *J Steroid Biochem* 24(1):77-83.
- Greene GL, Gilna P, Waterfield M, Baker A, Hort Y, Shine J. 1986. Sequence and expression of human estrogen receptor complementary DNA. *Science* 231(4742):1150-1154.

- Guler HP, Zapf J, Scheiwiller E, Froesch ER. 1988. Recombinant human insulin-like growth factor I stimulates growth and has distinct effects on organ size in hypophysectomized rats. *Proc Natl Acad Sci U S A* 85(13):4889-4893.
- Hargest TE, Leach RM, Gay CV. 1985. Avian tibial dyschondroplasia. I. Ultrastructure. *Am J Pathol* 119(2):175-190.
- Hazebroek-Kampschreur AA, Hofman A, van Dijk AP, van Ling B. 1994. Determinants of trunk abnormalities in adolescence. *Int J Epidemiol* 23(6):1242-1247.
- Heino TJ, Chagin AS, Takigawa M, Savendahl L. 2008. Effects of alendronate and pamidronate on cultured rat metatarsal bones: failure to prevent dexamethasone-induced growth retardation. *Bone* 42(4):702-709.
- Hero M, Makitie O, Kroger H, Nousiainen E, Toiviainen-Salo S, Dunkel L. 2009. Impact of aromatase inhibitor therapy on bone turnover, cortical bone growth and vertebral morphology in pre- and peripubertal boys with idiopathic short stature. *Horm Res* 71(5):290-297.
- Hero M, Norjavaara E, Dunkel L. 2005. Inhibition of estrogen biosynthesis with a potent aromatase inhibitor increases predicted adult height in boys with idiopathic short stature: a randomized controlled trial. *J Clin Endocrinol Metab* 90(12):6396-6402.
- Hindmarsh PC, Pringle PJ, Di Silvio L, Brook CG. 1990. A preliminary report on the role of somatostatin analogue (SMS 201-995) in the management of children with tall stature. *Clin Endocrinol (Oxf)* 32(1):83-91.
- Holtrop M. Origin of bone cells in endochondral ossification in calcified tissue; 1966; Davos, Switzerland. New York: Springer-Verlag. p 32-36.
- Honnebier WJ, Swaab DF. 1973. The influence of anencephaly upon intrauterine growth of fetus and placenta and upon gestation length. *J Obstet Gynaecol Br Commonw* 80(7):577-588.
- Horton WA. 2006. Skeletal development. In: Unsicker K, Kriegelstein K, editors. *Cell signaling and growth factors in development*. Weinheim: Wiley-VCH verlag-GmbH. p 619-640.
- Horton WA, Hall JG, Hecht JT. 2007. Achondroplasia. *Lancet* 370(9582):162-172.
- Ignatius A, Lenko HL, Perheentupa J. 1991. Oestrogen treatment of tall girls: effect decreases with age. *Acta Paediatr Scand* 80(6-7):712-717.
- Isaksson OG, Lindahl A, Nilsson A, Isgaard J. 1987. Mechanism of the stimulatory effect of growth hormone on longitudinal bone growth. *Endocr Rev* 8(4):426-438.
- Ishizaki Y, Burne JF, Raff MC. 1994. Autocrine signals enable chondrocytes to survive in culture. *J Cell Biol* 126(4):1069-1077.
- Ishizaki Y, Cheng L, Mudge AW, Raff MC. 1995. Programmed cell death by default in embryonic cells, fibroblasts, and cancer cells. *Mol Biol Cell* 6(11):1443-1458.
- Joseph E, Raine MDCD, John W Gregory, Martin O Savage and Raymond L Hintz. 2005. *Practical Endocrinology and Diabetes in Children*. In: Brown A, editor. *Practical endocrinology and diabetes in children*. Malden, Massachusetts, USA: Blackwell publishing Ltd p42-64.
- Kaplan SL, Grumbach MM, Shepard TH. 1972. The ontogenesis of human fetal hormones. I. Growth hormone and insulin. *J Clin Invest* 51(12):3080-3093.
- Karimian E, Chagin AS, Gjerde J, Heino T, Lien EA, Ohlsson C, Savendahl L. 2008. Tamoxifen impairs both longitudinal and cortical bone growth in young male rats. *J Bone Miner Res* 23(8):1267-1277.
- Kisanga ER, Gjerde J, Schjott J, Mellgren G, Lien EA. 2003. Tamoxifen administration and metabolism in nude mice and nude rats. *J Steroid Biochem Mol Biol* 84(2-3):361-367.
- Kobayashi T, Soegiarto DW, Yang Y, Lanske B, Schipani E, McMahon AP, Kronenberg HM. 2005. Indian hedgehog stimulates periarticular chondrocyte differentiation to regulate growth plate length independently of PTHrP. *J Clin Invest* 115(7):1734-1742.
- Krege JH, Hodgin JB, Couse JF, Enmark E, Warner M, Mahler JF, Sar M, Korach KS, Gustafsson JA, Smithies O. 1998. Generation and reproductive phenotypes of

- mice lacking estrogen receptor beta. *Proc Natl Acad Sci U S A* 95(26):15677-15682.
- Kreher NC. 2009. Effects of tamoxifen on predicted adult height in pubertal, growth hormone deficient boys: a pilot study. In: Czernichow P, editor. *LWPES/ESPE 8th Joint Meeting in Pediatric Endocrinology*. New York, USA: Hormone Research. p (278-278).
- Kreher NC, Eugster EA, Shankar RR. 2005. The use of tamoxifen to improve height potential in short pubertal boys. *Pediatrics* 116(6):1513-1515.
- Kronenberg HM. 2003. Developmental regulation of the growth plate. *Nature* 423(6937):332-336.
- Kuiper GG, Enmark E, Peltö-Huikko M, Nilsson S, Gustafsson JA. 1996. Cloning of a novel receptor expressed in rat prostate and ovary. *Proc Natl Acad Sci U S A* 93(12):5925-5930.
- Kusec V, Virdi AS, Prince R, Triffitt JT. 1998. Localization of estrogen receptor-alpha in human and rabbit skeletal tissues. *J Clin Endocrinol Metab* 83(7):2421-2428.
- Lai LP, Mitchell J. 2005. Indian hedgehog: its roles and regulation in endochondral bone development. *J Cell Biochem* 96(6):1163-1173.
- Lawrence SE, Faught KA, Vethamuthu J, Lawson ML. 2004. Beneficial effects of raloxifene and tamoxifen in the treatment of pubertal gynecomastia. *J Pediatr* 145(1):71-76.
- Lazarus JE, Hegde A, Andrade AC, Nilsson O, Baron J. 2007. Fibroblast growth factor expression in the postnatal growth plate. *Bone* 40(3):577-586.
- Lee ER, Lamplugh L, Shepard NL, Mort JS. 1995. The septoclast, a cathepsin B-rich cell involved in the resorption of growth plate cartilage. *J Histochem Cytochem* 43(5):525-536.
- Li X, Takahashi M, Kushida K, Koyama S, Hoshino H, Kawana K, Horiuchi K, Inoue T. 1996. The effect of tamoxifen on bone metabolism and skeletal growth is different in ovariectomized and intact rats. *Calcif Tissue Int* 59(4):271-276.
- Lien EA, Solheim E, Ueland PM. 1991. Distribution of tamoxifen and its metabolites in rat and human tissues during steady-state treatment. *Cancer Res* 51(18):4837-4844.
- Lindberg MK, Alatalo SL, Halleen JM, Mohan S, Gustafsson JA, Ohlsson C. 2001. Estrogen receptor specificity in the regulation of the skeleton in female mice. *J Endocrinol* 171(2):229-236.
- Liu JP, Baker J, Perkins AS, Robertson EJ, Efstratiadis A. 1993. Mice carrying null mutations of the genes encoding insulin-like growth factor I (Igf-1) and type 1 IGF receptor (Igf1r). *Cell* 75(1):59-72.
- Livne E, Weiss A, Silbermann M. 1988. Differentiation of cartilage cells studied by quantitative [³H]thymidine autoradiography in vitro. *Cell Differ* 23(1-2):61-67.
- Long F, Chung UI, Ohba S, McMahon J, Kronenberg HM, McMahon AP. 2004. Ihh signaling is directly required for the osteoblast lineage in the endochondral skeleton. *Development* 131(6):1309-1318.
- Lubahn DB, Moyer JS, Golding TS, Couse JF, Korach KS, Smithies O. 1993. Alteration of reproductive function but not prenatal sexual development after insertional disruption of the mouse estrogen receptor gene. *Proc Natl Acad Sci U S A* 90(23):11162-11166.
- Magne D, Bluteau G, Faucheux C, Palmer G, Vignes-Colombeix C, Pilet P, Rouillon T, Caverzasio J, Weiss P, Daculsi G, Guicheux J. 2003. Phosphate is a specific signal for ATDC5 chondrocyte maturation and apoptosis-associated mineralization: possible implication of apoptosis in the regulation of endochondral ossification. *J Bone Miner Res* 18(8):1430-1442.
- Mansfield K, Rajpurohit R, Shapiro IM. 1999. Extracellular phosphate ions cause apoptosis of terminally differentiated epiphyseal chondrocytes. *J Cell Physiol* 179(3):276-286.
- Mascie-Taylor CG. 1991. Biosocial influences on stature: a review. *J Biosoc Sci* 23(1):113-128.
- Mauras N, Gonzalez de Pijem L, Hsiang HY, Desrosiers P, Rapaport R, Schwartz ID, Klein KO, Singh RJ, Miyamoto A, Bishop K. 2008. Anastrozole increases predicted adult height of short adolescent males treated with growth hormone: a

- randomized, placebo-controlled, multicenter trial for one to three years. *J Clin Endocrinol Metab* 93(3):823-831.
- Melmed S. 1999. Insulin-like growth factor I--a prototypic peripheral-paracrine hormone? *Endocrinology* 140(9):3879-3880.
- Melrose J, Hayes AJ, Whitelock JM, Little CB. 2008. Perlecan, the "jack of all trades" proteoglycan of cartilaginous weight-bearing connective tissues. *Bioessays* 30(5):457-469.
- Minina E, Kreschel C, Naski MC, Ornitz DM, Vortkamp A. 2002. Interaction of FGF, Ihh/Pthlh, and BMP signaling integrates chondrocyte proliferation and hypertrophic differentiation. *Dev Cell* 3(3):439-449.
- Minina E, Wenzel HM, Kreschel C, Karp S, Gaffield W, McMahon AP, Vortkamp A. 2001. BMP and Ihh/PTHrP signaling interact to coordinate chondrocyte proliferation and differentiation. *Development* 128(22):4523-4534.
- Moodbidri MS, Shirsat NV. 2005. Activated JNK brings about accelerated apoptosis of Bcl-2-overexpressing C6 glioma cells on treatment with tamoxifen. *J Neurochem* 92(1):1-9.
- Morishima A, Grumbach MM, Simpson ER, Fisher C, Qin K. 1995. Aromatase deficiency in male and female siblings caused by a novel mutation and the physiological role of estrogens. *J Clin Endocrinol Metab* 80(12):3689-3698.
- Morris NP. 2002. Morphology and chemical composition of connective tissue: cartilage. P.M R, Steinmann B, editors.: Wiley-Liss.
- Mushtaq T, Bijman P, Ahmed SF, Farquharson C. 2004. Insulin-like growth factor-I augments chondrocyte hypertrophy and reverses glucocorticoid-mediated growth retardation in fetal mice metatarsal cultures. *Endocrinology* 145(5):2478-2486.
- Mårtensson K, Chrysis D, Sävendahl L. 2004. Interleukin-1beta and TNF-alpha act in synergy to inhibit longitudinal growth in fetal rat metatarsal bones. *J Bone Miner Res* 19(11):1805-1812.
- Nilsson LO, Boman A, Savendahl L, Grigelioniene G, Ohlsson C, Ritzen EM, Wroblewski J. 1999. Demonstration of estrogen receptor-beta immunoreactivity in human growth plate cartilage. *J Clin Endocrinol Metab* 84(1):370-373.
- Nilsson O, Abad V, Chrysis D, Ritzen EM, Savendahl L, Baron J. 2002. Estrogen receptor-alpha and -beta are expressed throughout postnatal development in the rat and rabbit growth plate. *J Endocrinol* 173(3):407-414.
- Nilsson O, Chrysis D, Pajulo O, Boman A, Holst M, Rubinstein J, Martin Ritzen E, Savendahl L. 2003a. Localization of estrogen receptors-alpha and -beta and androgen receptor in the human growth plate at different pubertal stages. *J Endocrinol* 177(2):319-326.
- Nilsson O, Falk J, Ritzen EM, Baron J, Savendahl L. 2003b. Raloxifene acts as an estrogen agonist on the rabbit growth plate. *Endocrinology* 144(4):1481-1485.
- Nilsson O, Marino R, De Luca F, Phillip M, Baron J. 2005. Endocrine regulation of the growth plate. *Horm Res* 64(4):157-165.
- O'Keefe RJ, Puzas JE, Loveys L, Hicks DG, Rosier RN. 1994. Analysis of type II and type X collagen synthesis in cultured growth plate chondrocytes by in situ hybridization: rapid induction of type X collagen in culture. *J Bone Miner Res* 9(11):1713-1722.
- Ornitz DM, Marie PJ. 2002. FGF signaling pathways in endochondral and intramembranous bone development and human genetic disease. *Genes Dev* 16(12):1446-1465.
- Oz OK, Millsaps R, Welch R, Birch J, Zerwekh JE. 2001. Expression of aromatase in the human growth plate. *J Mol Endocrinol* 27(2):249-253.
- Panteon E, Loumaye E, Maes M, Malvaux P. 1988. Occurrence of prolactinoma after estrogen treatment in a girl with constitutional tall stature. *J Pediatr* 113(2):337-339.
- Parikka V, Peng Z, Hentunen T, Risteli J, Elo T, Vaananen HK, Harkonen P. 2005. Estrogen responsiveness of bone formation in vitro and altered bone phenotype in aged estrogen receptor-alpha-deficient male and female mice. *Eur J Endocrinol* 152(2):301-314.
- Pendaries C, Darblade B, Rochemaix P, Krust A, Chambon P, Korach KS, Bayard F, Arnal JF. 2002. The AF-1 activation-function of ERalpha may be dispensable to

- mediate the effect of estradiol on endothelial NO production in mice. *Proc Natl Acad Sci U S A* 99(4):2205-2210.
- Perry MJ, Gujra S, Whitworth T, Tobias JH. 2005. Tamoxifen stimulates cancellous bone formation in long bones of female mice. *Endocrinology* 146(3):1060-1065.
- Pizette S, Niswander L. 2000. BMPs are required at two steps of limb chondrogenesis: formation of prechondrogenic condensations and their differentiation into chondrocytes. *Dev Biol* 219(2):237-249.
- Prader A, Zachmann M. 1978. Treatment of excessively tall girls and boys with sex hormones. *Pediatrics* 62(6 Pt 2):1202-1210.
- Ren SG, Malozowski S, Sanchez P, Sweet DE, Loriaux DL, Cassorla F. 1989. Direct administration of testosterone increases rat tibial epiphyseal growth plate width. *Acta Endocrinol (Copenh)* 121(3):401-405.
- Revankar CM, Cimino DF, Sklar LA, Arterburn JB, Prossnitz ER. 2005. A transmembrane intracellular estrogen receptor mediates rapid cell signaling. *Science* 307(5715):1625-1630.
- Riggs BL, Hartmann LC. 2003. Selective estrogen-receptor modulators -- mechanisms of action and application to clinical practice. *N Engl J Med* 348(7):618-629.
- Roach HI, Aigner T, Kouri JB. 2004. Chondroptosis: a variant of apoptotic cell death in chondrocytes? *Apoptosis* 9(3):265-277.
- Roach HI, Erenpreisa J. 1996. The phenotypic switch from chondrocytes to bone-forming cells involves asymmetric cell division and apoptosis. *Connect Tissue Res* 35(1-4):85-91.
- Robinson SP, Langan-Fahey SM, Johnson DA, Jordan VC. 1991. Metabolites, pharmacodynamics, and pharmacokinetics of tamoxifen in rats and mice compared to the breast cancer patient. *Drug Metab Dispos* 19(1):36-43.
- Rodd C, Jourdain N, Alini M. 2004. Action of estradiol on epiphyseal growth plate chondrocytes. *Calcif Tissue Int* 75(3):214-224.
- Scheven BA, Hamilton NJ. 1991. Longitudinal bone growth in vitro: effects of insulin-like growth factor I and growth hormone. *Acta Endocrinol (Copenh)* 124(5):602-607.
- Shakibaei M, Harikumar KB, Aggarwal BB. 2009. Resveratrol addiction: to die or not to die. *Mol Nutr Food Res* 53(1):115-128.
- Shapiro IM, Adams CS, Freeman T, Srinivas V. 2005. Fate of the hypertrophic chondrocyte: microenvironmental perspectives on apoptosis and survival in the epiphyseal growth plate. *Birth Defects Res C Embryo Today* 75(4):330-339.
- Silbermann M, Reddi AH, Hand AR, Leapman R, von der Mark K, Franzen A. 1987. Chondroid bone arises from mesenchymal stem cells in organ culture of mandibular condyles. *J Craniofac Genet Dev Biol* 7(1):59-79.
- Silvestrini G, Mocetti P, Ballanti P, Di Grezia R, Bonucci E. 1999. Cytochemical demonstration of the glucocorticoid receptor in skeletal cells of the rat. *Endocr Res* 25(1):117-128.
- Sims NA, Dupont S, Krust A, Clement-Lacroix P, Minet D, Resche-Rigon M, Gaillard-Kelly M, Baron R. 2002. Deletion of estrogen receptors reveals a regulatory role for estrogen receptors-beta in bone remodeling in females but not in males. *Bone* 30(1):18-25.
- Slemenda CW, Longcope C, Zhou L, Hui SL, Peacock M, Johnston CC. 1997. Sex steroids and bone mass in older men. Positive associations with serum estrogens and negative associations with androgens. *J Clin Invest* 100(7):1755-1759.
- Smink JJ, Gresnigt MG, Hamers N, Koedam JA, Berger R, Van Buul-Offers SC. 2003. Short-term glucocorticoid treatment of prepubertal mice decreases growth and IGF-I expression in the growth plate. *J Endocrinol* 177(3):381-388.
- Smith EP, Boyd J, Frank GR, Takahashi H, Cohen RM, Specker B, Williams TC, Lubahn DB, Korach KS. 1994. Estrogen resistance caused by a mutation in the estrogen-receptor gene in a man. *N Engl J Med* 331(16):1056-1061.
- Smith EP, Specker B, Bachrach BE, Kimbro KS, Li XJ, Young MF, Fedarko NS, Abuzzahab MJ, Frank GR, Cohen RM, Lubahn DB, Korach KS. 2008. Impact on bone of an estrogen receptor-alpha gene loss of function mutation. *J Clin Endocrinol Metab* 93(8):3088-3096.

- St-Jacques B, Hammerschmidt M, McMahon AP. 1999. Indian hedgehog signaling regulates proliferation and differentiation of chondrocytes and is essential for bone formation. *Genes Dev* 13(16):2072-2086.
- Stanhope R, Buchanan CR, Fenn GC, Preece MA. 1988. Double blind placebo controlled trial of low dose oxandrolone in the treatment of boys with constitutional delay of growth and puberty. *Arch Dis Child* 63(5):501-505.
- Steinert AF, Proffen B, Kunz M, Hendrich C, Ghivizzani SC, Noth U, Rethwilm A, Eulert J, Evans CH. 2009. Hypertrophy is induced during the in vitro chondrogenic differentiation of human mesenchymal stem cells by bone morphogenetic protein-2 and bone morphogenetic protein-4 gene transfer. *Arthritis Res Ther* 11(5):R148.
- Storm EE, Kingsley DM. 1999. GDF5 coordinates bone and joint formation during digit development. *Dev Biol* 209(1):11-27.
- Stratikopoulos E, Szabolcs M, Dragatsis I, Klinakis A, Efstratiadis A. 2008. The hormonal action of IGF1 in postnatal mouse growth. *Proc Natl Acad Sci U S A* 105(49):19378-19383.
- Sylvia VL, Gay I, Hardin R, Dean DD, Boyan BD, Schwartz Z. 2002. Rat costochondral chondrocytes produce 17beta-estradiol and regulate its production by 1alpha,25(OH)(2)D(3). *Bone* 30(1):57-63.
- Takigawa M, Tajima K, Pan HO, Enomoto M, Kinoshita A, Suzuki F, Takano Y, Mori Y. 1989. Establishment of a clonal human chondrosarcoma cell line with cartilage phenotypes. *Cancer Res* 49(14):3996-4002.
- Tanner JM, O'Keeffe B. 1962. Age at menarche in Nigerian school girls, with a note on their heights and weights from age 12 to 19. *Hum Biol* 34:187-196.
- Toledo-Pereyra LH, Toledo AH, Walsh J, Lopez-Neblina F. 2004. Molecular signaling pathways in ischemia/reperfusion. *Exp Clin Transplant* 2(1):174-177.
- Toma JG, Akhavan M, Fernandes KJ, Barnabe-Heider F, Sadikot A, Kaplan DR, Miller FD. 2001. Isolation of multipotent adult stem cells from the dermis of mammalian skin. *Nat Cell Biol* 3(9):778-784.
- Tozum TF, Oppenlander ME, Koh-Paige AJ, Robins DM, McCauley LK. 2004. Effects of sex steroid receptor specificity in the regulation of skeletal metabolism. *Calcif Tissue Int* 75(1):60-70.
- Turner RT, Evans GL, Zhang M, Maran A, Sibonga JD. 1999. Is resveratrol an estrogen agonist in growing rats? *Endocrinology* 140(1):50-54.
- van der Eerden BC, Karperien M, Wit JM. 2003. Systemic and local regulation of the growth plate. *Endocr Rev* 24(6):782-801.
- van der Eerden BC, van de Ven J, Lowik CW, Wit JM, Karperien M. 2002. Sex steroid metabolism in the tibial growth plate of the rat. *Endocrinology* 143(10):4048-4055.
- Wang Y, Lee KW, Chan FL, Chen S, Leung LK. 2006. The red wine polyphenol resveratrol displays bilevel inhibition on aromatase in breast cancer cells. *Toxicol Sci* 92(1):71-77.
- Waters MJ, Kaye PL. 2002. The role of growth hormone in fetal development. *Growth Horm IGF Res* 12(3):137-146.
- Weimann E, Brack C. 1996. Severe thrombosis during treatment with ethinylestradiol for tall stature. *Horm Res* 45(6):261-263.
- Weise M, De-Levi S, Barnes KM, Gafni RI, Abad V, Baron J. 2001. Effects of estrogen on growth plate senescence and epiphyseal fusion. *Proc Natl Acad Sci U S A* 98(12):6871-6876.
- Weiss A, Livne E, Brandeis E, Silbermann M. 1988a. Triamcinolone impairs the synthesis of collagen and noncollagen proteins in condylar cartilage of newborn mice. *Calcif Tissue Int* 42(1):63-69.
- Weiss A, Livne E, von der Mark K, Heinegard D, Silbermann M. 1988b. Growth and repair of cartilage: organ culture system utilizing chondroprogenitor cells of condylar cartilage in newborn mice. *J Bone Miner Res* 3(1):93-100.
- Veldhuis JD, Metzger DL, Martha PM, Jr., Mauras N, Kerrigan JR, Keenan B, Rogol AD, Pincus SM. 1997. Estrogen and testosterone, but not a nonaromatizable androgen, direct network integration of the hypothalamo-somatotrope (growth hormone)-insulin-like growth factor I axis in the human: evidence from

- pubertal pathophysiology and sex-steroid hormone replacement. *J Clin Endocrinol Metab* 82(10):3414-3420.
- Venn A BF, Werther G. 2005. Estrogen Treatment to Reduce the Adult Height of Tall Girls: Long-Term Effects on Fertility. *Obstetric Gynecology Survey*(60):306-307.
- Venn A, Bruinsma F, Werther G, Pyett P, Baird D, Jones P, Rayner J, Lumley J. 2004. Oestrogen treatment to reduce the adult height of tall girls: long-term effects on fertility. *Lancet* 364(9444):1513-1518.
- Venn A, Hosmer T, Hosmer D, Bruinsma F, Jones P, Lumley J, Pyett P, Rayner JA, Werther G. 2008. Oestrogen treatment for tall stature in girls: estimating the effect on height and the error in height prediction. *Clin Endocrinol (Oxf)* 68(6):926-929.
- Werder EA, Waibel P, Sege D, Flury R. 1990. Severe thrombosis during oestrogen treatment for tall stature. *Eur J Pediatr* 149(6):389-390.
- Vidal O, Lindberg M, Savendahl L, Lubahn DB, Ritzen EM, Gustafsson JA, Ohlsson C. 1999. Disproportional body growth in female estrogen receptor-alpha-inactivated mice. *Biochem Biophys Res Commun* 265(2):569-571.
- Vidal O, Lindberg MK, Hollberg K, Baylink DJ, Andersson G, Lubahn DB, Mohan S, Gustafsson JA, Ohlsson C. 2000. Estrogen receptor specificity in the regulation of skeletal growth and maturation in male mice. *Proc Natl Acad Sci U S A* 97(10):5474-5479.
- Windahl SH, Andersson N, Chagin AS, Martensson UE, Carlsten H, Olde B, Swanson C, Moverare-Skrtic S, Savendahl L, Lagerquist MK, Leeb-Lundberg LM, Ohlsson C. 2009. The role of the G protein-coupled receptor GPR30 in the effects of estrogen in ovariectomized mice. *Am J Physiol Endocrinol Metab* 296(3):E490-496.
- Windahl SH, Hollberg K, Vidal O, Gustafsson JA, Ohlsson C, Andersson G. 2001. Female estrogen receptor beta-/- mice are partially protected against age-related trabecular bone loss. *J Bone Miner Res* 16(8):1388-1398.
- Windahl SH, Vidal O, Andersson G, Gustafsson JA, Ohlsson C. 1999. Increased cortical bone mineral content but unchanged trabecular bone mineral density in female ERbeta(-/-) mice. *J Clin Invest* 104(7):895-901.
- Woods KA, Camacho-Hubner C, Savage MO, Clark AJ. 1996. Intrauterine growth retardation and postnatal growth failure associated with deletion of the insulin-like growth factor I gene. *N Engl J Med* 335(18):1363-1367.
- Wu X, Ahn EY, McKenna MA, Yeo H, McDonald JM. 2005. Fas binding to calmodulin regulates apoptosis in osteoclasts. *J Biol Chem* 280(33):29964-29970.
- Yakar S, Rosen CJ, Bouxsein ML, Sun H, Mejia W, Kawashima Y, Wu Y, Emerton K, Williams V, Jepsen K, Schaffler MB, Majeska RJ, Gavrilova O, Gutierrez M, Hwang D, Pennisi P, Frystyk J, Boisclair Y, Pintar J, Jasper H, Domene H, Cohen P, Clemmons D, LeRoith D. 2009. Serum complexes of insulin-like growth factor-1 modulate skeletal integrity and carbohydrate metabolism. *FASEB J* 23(3):709-719.
- Zirilli L, Maffei L, Meunier PJ, Chavassieux P, Carani C, Rochira V. 2009. The effects of long-term raloxifene and estradiol treatments on bone in a patient with congenital aromatase deficiency. *Bone* 45(5):827-832.
- Zuzarte-Luis V, Hurler JM. 2002. Programmed cell death in the developing limb. *Int J Dev Biol* 46(7):871-876.