

From the Department of Medical Epidemiology and Biostatistics  
Karolinska Institutet, Stockholm, Sweden

# THE ORIGINS AND CONSEQUENCES OF ATTENTION DEFICIT HYPERACTIVITY DISORDER

Zheng Chang



**Karolinska  
Institutet**

Stockholm 2013

All previously published papers were reproduced with permission from the publisher.

Published by Karolinska Institutet. Printed by Larserics Digital Print AB.

© Zheng Chang, 2013

ISBN 978-91-7549-324-4

## **ABSTRACT**

Attention deficit hyperactivity disorder (ADHD) is characterized by developmentally inappropriate levels of inattention, hyperactivity, and impulsivity, and is the most common neurodevelopmental disorder of childhood. This highly prevalent disorder is estimated to affect about 5% of school-age children worldwide, with a substantial degree of persistence over time. Although the specific cause of ADHD is still largely unknown, despite a long history of research, it is believed to involve multiple genetic and environmental factors. ADHD is also associated with considerable comorbidities and functional impairments, which place a substantial burden on affected individuals, their families and society. Stimulant medication is considered as one of the most important treatments for ADHD, but the increased use over the years has also raised numerous public concerns. Therefore, the general aim of this thesis was to investigate how genetic and environmental factors contribute to the development of ADHD, as well as to investigate the consequences of ADHD and potential effects of ADHD medication.

Study I explored the relative contribution of genetic and environmental influences of ADHD from childhood through early adulthood. The study found that the shared view of self- and informant-rated ADHD is highly heritable in childhood, adolescence, and early adulthood. It also found evidence of both stable and dynamic genetic influences on ADHD over the course of the development.

Study II examined the association between young maternal age at childbearing and subsequent risk for ADHD in offspring, using a genetically-informative design. The study found that maternal age at first birth, not maternal age at the current birth, predicted offspring ADHD. Thus, all offspring born to teenage mothers were at increased risk of ADHD. The association was mainly explained by passive gene-environment correlations. That is, genetic factors transmitted from mothers to children contribute to both mothers' age at childbearing and ADHD in offspring.

Study III investigated how the two symptom dimensions of ADHD (hyperactivity-impulsivity and inattention) are associated with early-onset substance use. The study found that that hyperactivity-impulsivity, but not inattention, independently predicted early-onset tobacco use, even after controlling for conduct problems. Twin analyses showed that the association between hyperactivity-impulsivity and early-onset substance use were mainly influenced by genetic factors.

Study IV estimated the association between ADHD and the risk of serious transport accidents, and explored the extent to which ADHD medication influenced this risk among ADHD patients. The study found that ADHD patients were at increased risk for serious transport accidents, and that ADHD medication was associated with a significant reduction of accidents, among males patients, even when using within-individual analyses to control for confounding.

Study V explored whether stimulant ADHD medication is associated with risk for long-term substance abuse. The study found no indication of increased substance abuse at follow-up. Rather, the results suggested there was a decrease in substance abuse for up to four years after taking ADHD medications, and that patients who took ADHD medication for longer durations had lower rates of substance abuse.

In conclusion, ADHD is a prevalent, persistent and impairing disorder. Genetic factors play an important role in the development of the disorder from childhood to adulthood. ADHD predicts poor developmental and health outcomes, and ADHD medications appear to be useful in reducing some serious adverse outcomes, such as transport accidents and substance abuse. The findings in this thesis highlight the importance of using quasi-experimental designs, including genetically-informative studies, when exploring how risk factors and adverse consequences are associated with ADHD.

## LIST OF PUBLICATIONS

This thesis is based on the following papers, which will be referred to in the text by their Roman numerals (I-V).

- I. Chang Z, Lichtenstein P, Asherson P, Larsson H. Developmental Twin Study of Attention Problems: High Heritabilities Throughout Development. *JAMA Psychiatry*. 2013 Mar 1;70(3):311-8.
- II. Chang Z, Lichtenstein P, D'Onofrio BM, Kuja-Halkola R, Sjölander A, Larsson H. Maternal age at childbirth and risk for ADHD in offspring: A genetically informative study. *Manuscript*.
- III. Chang Z, Lichtenstein P, Larsson H. The effects of childhood ADHD symptoms on early-onset substance use: A Swedish twin study. *Journal of Abnormal Child Psychology*. 2012 Apr;40(3):425-35.
- IV. Chang Z, Lichtenstein P, D'Onofrio BM, Sjölander A, Larsson H. Serious transport accidents in adults with ADHD, and the effect of medication: A population based study. *JAMA Psychiatry*, in press.
- V. Chang Z, Lichtenstein P, Halldner L, D'Onofrio BM, Serlachius E, Fazel S, Långström N, Larsson H. Stimulant ADHD medication and risk for substance abuse. *Journal of Child Psychology and Psychiatry*, in press.

# CONTENTS

|       |  |    |
|-------|--|----|
| 1     | Introduction .....   | 1  |
| 1.1   | ADHD.....  | 1  |
| 1.1.1 | Diagnosis .....  | 1  |
| 1.1.2 | Prevalence .....   | 4  |
| 1.1.3 | Persistence .....  | 5  |
| 1.1.4 | Neurobiology.....  | 6  |
| 1.2   | Origins .....  | 6  |
| 1.2.1 | Genetic risk factors .....                                   | 6  |
| 1.2.2 | Environmental risk factors.....                              | 7  |
| 1.3   | Consequences .....   | 8  |
| 1.3.1 | Psychiatric comorbidity .....                                | 8  |
| 1.3.2 | Functional impairment.....                                   | 9  |
| 1.4   | Treatment of ADHD.....                                       | 9  |
| 1.5   | Specific Research questions.....                             | 11 |
| 1.5.1 | Heritability of ADHD throughout development .....            | 11 |
| 1.5.2 | Young maternal age and offspring ADHD .....                  | 11 |
| 1.5.3 | ADHD and early-onset substance use .....                     | 12 |
| 1.5.4 | ADHD, transport accidents, and the effect of medication ..   | 13 |
| 1.5.5 | ADHD medication and risk of substance abuse.....             | 13 |
| 2     | Aims.....  | 14 |
| 3     | Study samples.....   | 15 |
| 3.1   | The Swedish Twin study of CHild and Adolescent Development . | 15 |
| 3.1.1 | Sample and Response Rate .....                               | 15 |
| 3.1.2 | Zygotity determination .....                                 | 15 |
| 3.1.3 | Measures.....  | 15 |
| 3.1.4 | Representativeness of the sample .....                       | 17 |
| 3.2   | Swedish national registers.....                              | 17 |
| 3.2.1 | National Patient Register .....                              | 17 |
| 3.2.2 | Multi-Generation Register .....                              | 17 |
| 3.2.3 | Medical Birth Register.....                                  | 18 |
| 3.2.4 | Prescribed Drug Register.....                                | 18 |
| 3.2.5 | Causes of Death Register.....                                | 18 |
| 4     | Study designs and methods.....                               | 19 |
| 4.1   | General methods.....   | 19 |
| 4.1.1 | Twin methodology .....                                       | 19 |
| 4.1.2 | Quasi-experimental designs.....                              | 20 |
| 4.2   | Study I.....   | 22 |
| 4.3   | Study II .....   | 23 |
| 4.4   | Study III.....   | 23 |
| 4.5   | Study IV.....  | 24 |
| 4.6   | Study V .....  | 25 |
| 5     | Results .....  | 27 |

|       |  |    |
|-------|--|----|
| 5.1   | Study I.....   | 27 |
| 5.2   | Study II.....  | 28 |
| 5.3   | Study III .....  | 29 |
| 5.4   | Study IV .....   | 31 |
| 5.5   | Study V .....  | 32 |
| 6     | Discussion.....  | 34 |
| 6.1   | Findings and implications.....                             | 34 |
| 6.1.1 | Heritability of ADHD throughout development .....          | 34 |
| 6.1.2 | Young maternal age and offspring ADHD.....                 | 35 |
| 6.1.3 | ADHD and early-onset substance use .....                   | 36 |
| 6.1.4 | ADHD, transport accidents, and the effect of medication .. | 36 |
| 6.1.5 | ADHD medication and risk of substance abuse.....           | 37 |
| 6.2   | Methodological considerations.....                         | 38 |
| 6.2.1 | Measurement issues.....                                    | 38 |
| 6.2.2 | Causal inference from observational data .....             | 40 |
| 6.2.3 | Twin methodological issues.....                            | 42 |
| 6.3   | Generalizability .....                                     | 43 |
| 7     | Conclusions.....   | 44 |
| 8     | Future perspectives .....                                  | 45 |
| 8.1   | Twin studies in the omics era.....                         | 45 |
| 8.2   | Beyond genetic and environmental risk factors.....         | 46 |
| 9     | Acknowledgements .....                                     | 47 |
| 10    | References.....  | 49 |

## LIST OF ABBREVIATIONS

|       |   |
|-------|---|
| ABCL  | Adult Behavior Checklist                              |
| ADHD  | Attention deficit hyperactivity disorder              |
| AP    | Attention Problems                                    |
| ASR   | Adult Self-Report                                     |
| ATC   | Anatomical Therapeutic Chemical classification system |
| CBCL  | Child Behavior Checklist                              |
| CD    | Conduct disorder                                      |
| CI    | Confidence intervals                                  |
| CoD   | Cause of Death Register                               |
| CoS   | Children of siblings                                  |
| CPB   | Conduct problem behavior                              |
| DSM   | Diagnostic and Statistical Manual of Mental Disorders |
| DZ    | Dizygotic   |
| GWAS  | Genome-wide association study                         |
| HI    | Hyperactivity-impulsivity                             |
| HKD   | Hyperkinetic disorder                                 |
| HR    | Hazard ratio  |
| ICD   | International Classification of Diseases              |
| IN    | Inattention   |
| MACB  | Maternal age at current birth                         |
| MAFB  | Maternal age at first birth                           |
| MBR   | Medical Birth Register                                |
| MGR   | Multi-Generation Register                             |
| MZ    | Monozygotic   |
| NPR   | National Patient Register                             |
| ODD   | Oppositional defiant disorder                         |
| OR    | Odds ratio  |
| PAF   | Population attributable fraction                      |
| PDR   | Prescribed Drug Register                              |
| rGE   | Gene-environmental correlation                        |
| RCT   | Randomized controlled trial                           |
| SDP   | Smoking during pregnancy                              |
| SEM   | Structural equation modeling                          |
| STR   | Swedish Twin Registry                                 |
| SUD   | Substance use disorder                                |
| TCHAD | Twin study of CHild and Adolescent Development        |
| TPR   | Total Population Register                             |
| WHO   | World Health Organization                             |
| YSR   | Youth Self-Report                                     |



# 1 INTRODUCTION

Attention deficit hyperactivity disorder (ADHD) is the most common neurodevelopmental disorder of childhood. This highly prevalent disorder is estimated to affect about 5% of school-age children worldwide, and it exhibits a substantial degree of persistence over time. ADHD is characterized by developmentally inappropriate levels of inattention, hyperactivity, and impulsivity, and is associated with considerable comorbidity and impairments. The etiology of ADHD is multifactorial and composed of multiple genetic and environmental factors. Because of its high prevalence and its associated impairments and adverse outcomes, ADHD is considered a major public health problem. Pharmacological treatment, including stimulant medication, plays an important role in the management of ADHD. The general aim of this thesis was to investigate how genetic and environmental factors contribute to the development of ADHD, as well as to investigate the consequences of ADHD and potential effects of ADHD medication.

## 1.1 ADHD

An early description of ADHD-like problem was made in 1798 by Scottish-born physician Sir Alexander Crichton, as "mental restlessness", a mental state that is much like the inattention symptom of ADHD today [1]. In 1902, British pediatrician Sir George Still described 43 children who had serious problems with sustained attention and self-regulation, which is considered to be the beginning of the modern conception of ADHD [2]. Since then, researchers and clinicians have been struggling to understand this disorder, and the terminology and diagnostic criteria used to describe the condition have changed over time. It was described as "minimal brain dysfunction" in the first edition of the Diagnostic and Statistical Manual of Mental Disorders (DSM-I, 1952), and "hyperkinetic reaction of childhood" in the DSM-II (1968). These early terms and criteria focused on the motoric hyperactivity and overt impulsivity of patients [3]. The DSM-III (1980) represented a paradigm shift, as it began to emphasize inattention as an important component of the disorder, and named it "attention-deficit disorder with or without hyperactivity"[4]. In 1987 the term was changed to Attention deficit hyperactivity disorder (ADHD) in the DSM-III-R [5] and this name continued to be used in the DSM-IV (1994) [6] and the new DSM-5 (2013) [7].

### 1.1.1 Diagnosis

In the past decade, the major clinical diagnostic systems for ADHD have been included in the DSM-IV [6] and the International Classification of Diseases, 10th edition (ICD-10) [8]. The DSM-IV diagnosis of ADHD is commonly used in North America, and the ICD-10 diagnosis is more commonly used in Europe. According to DSM-IV, individuals with ADHD show a persistent pattern of inattention and/or hyperactivity-impulsivity that interferes with their functioning or development (Table 1). Based on the prominence of the types of symptoms, three subtypes of ADHD are defined: predominantly inattentive, predominantly hyperactive-impulsive, and combined type.

Table 1. The DSM-IV diagnostic criteria for ADHD

---

- A. Either (1) or (2):
- (1) six (or more) of the following symptoms of inattention have persisted for at least six months to a degree that is maladaptive and inconsistent with developmental level:
    - (1) often fails to give close attention to details or makes careless mistakes in school work, work or other activities
    - (2) often has difficulty sustaining attention in tasks or play activities
    - (3) often does not seem to listen when spoken to directly
    - (4) often does not follow through on instructions and fails to finish school work, chores, or duties in the workplace (not due to oppositional behavior or failure to understand instructions)
    - (5) often has difficulty organizing tasks and activities
    - (6) often avoids, dislikes, or is reluctant to engage in tasks that require sustained mental effort (such as school work or homework)
    - (7) often loses things necessary for tasks or activities (e.g., toys, school assignments, pencils, books or tools)
    - (8) is often easily distracted by extraneous stimuli
    - (9) is often forgetful in daily activities
  - (2) six (or more) of the following symptoms of hyperactivity-impulsivity have persisted for at least six months to a degree that is maladaptive and inconsistent with developmental level:
    - (1) often fidgets with hands or feet or squirms in seat
    - (2) often leaves seat in classroom or in other situations in which remaining seated is expected
    - (3) often runs about or climbs excessively in situations in which it is inappropriate (in adolescents or adults, may be limited to subjective feelings of restlessness)
    - (4) often has difficulty playing or engaging in leisure activities quietly
    - (5) is often "on the go" or often acts as if driven by a motor
    - (6) often talks excessively
    - (7) often blurts out answers before questions have been completed
    - (8) often has difficulty awaiting turn
    - (9) often interrupts or intrudes on others (e.g., butts into conversations or games)
- B. Some hyperactive-impulsive or inattentive symptoms that caused impairment were present before age seven years.
- C. Some impairment from the symptoms is present in two or more settings (e.g., at school [or work] and at home).
- D. There must be clear evidence of clinically significant impairment in social, academic, or occupational functioning.
- E. The symptoms do not occur exclusively during the course of a pervasive developmental disorder, schizophrenia or other psychotic disorder and are not better accounted for by another mental disorder (e.g., mood disorder, anxiety disorder, dissociative disorder, or a personality disorder).
- 

The ICD-10 refers to ADHD as "hyperkinetic disorder" (HKD, code: F90). The two diagnostic systems include essentially the same list of symptoms, and both take into account the symptoms and impairments (Table 2). However, the ICD-10 criteria are more restrictive than the DSM-IV diagnosis of ADHD [9], because a diagnosis of HKD requires impairments in all three symptom domains, together with stricter exclusion criteria. HKD is, therefore, considered a severe form of ADHD, somewhat similar to DSM-IV combined subtype.

Table 2. The ICD-10 diagnostic criteria for hyperkinetic disorder

---

G1 Inattention

At least six of the following symptoms of attention have persisted for at least six months, to a degree that is maladaptive and inconsistent with the developmental level of the child:

- (1) often fails to give close attention to details, or makes careless errors in school work, work or other activities
- (2) often fails to sustain attention in tasks or play activities
- (3) often appears not to listen to what is being said to him or her
- (4) often does not follow through on instructions and fails to finish school work, chores, or duties in the workplace (not due to oppositional behavior or failure to understand instructions)
- (5) often fails to follow through on instructions or to finish school work, chores, or duties in the workplace (not because of oppositional behavior or failure to understand instructions)
- (6) often avoids or strongly dislikes tasks, such as homework, that require sustained mental effort
- (7) often loses things necessary for certain tasks and activities, such as school assignments, pencils, books, toys or tools
- (8) is often easily distracted by external stimuli
- (9) is often forgetful in the course of daily activities

G2 Hyperactivity

At least three of the following symptoms of hyperactivity have persisted for at least six months, to a degree that is maladaptive and inconsistent with the developmental level of the child:

- (1) often fidgets with hands or feet or squirms on seat
- (2) leaves seat in classroom or in other situations in which remaining seated is expected
- (3) often runs about or climbs excessively in situations in which it is inappropriate (in adolescents or adults, only feelings of restlessness may be present)
- (4) is often unduly noisy in playing or has difficulty in engaging quietly in leisure activities
- (5) exhibits a persistent pattern of excessive motor activity that is not substantially modified by social context or demands

G3 Impulsivity

At least one of the following symptoms of impulsivity has persisted for at least six months, to a degree that is maladaptive and inconsistent with the developmental level of the child:

- (1) often blurts out answers before questions have been completed
- (2) often fails to wait in lines or await turns in games or group situations
- (3) often interrupts or intrudes on others (e.g., butts into others' conversations or games)
- (4) often talks excessively without appropriate response to social constraints

G4 Onset of the disorder is no later than the age of seven years.

G5 The criteria should be met for more than a single situation, e.g., the combination of inattention and hyperactivity should be present both at home and at school, or at both school and another setting where children are observed, such as a clinic. (Evidence for cross-situationality will ordinarily require information from more than one source; parental reports about classroom behavior, for instance, are unlikely to be sufficient.)

G6 The symptoms in G1 and G3 cause clinically significant distress or impairment in social, academic, or occupational functioning.

G7 The disorder does not meet the criteria for pervasive developmental disorders (F84.-), manic episode (F30.-), depressive episode (F32.-), or anxiety disorders (F41.-).

---

While clinical diagnostic classification helps clinicians to identify patients that need help, and thereby, to provide treatment and care, there is a long-standing debate whether mental disorders are discrete clinical conditions or arbitrary distinctions along dimensions of functioning. It has been proposed that most mental disorders (including ADHD) may be better represented as quantitative dimensions rather than distinct categories [10,11], and this argument is supported by research that demonstrates etiological similarities across clinical-diagnosed ADHD and the full range of symptoms of inattention, hyperactivity and impulsivity [12,13]. Therefore, ADHD may be viewed as the extreme end of a behavioral continuum. In addition to DSM and ICD criteria, several rating scales have been developed to provide an in-depth assessment of ADHD that complements diagnostic evaluation [14]. Some of the most widely used rating scales are: the ADHD Rating Scale, the Conners' Rating Scales, the Swanson Nolan and Pelham Questionnaire, the Vanderbilt ADHD Rating Scales, and the Adult ADHD Self-Report Scale.

### 1.1.2 Prevalence

ADHD is highly prevalent worldwide, estimated to affect about 5% of school-age children [15,16] and about 2-4% of adults [17,18]. Although there is substantial geographic variability in the prevalence of ADHD, this variability seems to be explained primarily by differences in the methodological characteristics of studies [15]. The DSM-IV diagnosis of ADHD produces higher estimates of prevalence than ICD diagnosis of HKD, because the ICD criteria are more restrictive. Surveys that estimate the prevalence of ADHD based on symptoms alone and do not adequately incorporate functional impairment also yield higher estimates. In addition, gender distribution of the sample affects the estimates of prevalence, since ADHD is more common in boys than girls [19]. The gender difference may be explained by referral bias or under-diagnosis in girls. Girls usually have more inattentive symptoms and less disruptive behaviors than boys, which may lead to lower rates of diagnosis [20]. This gender difference is less pronounced in community samples than in clinical samples [21].

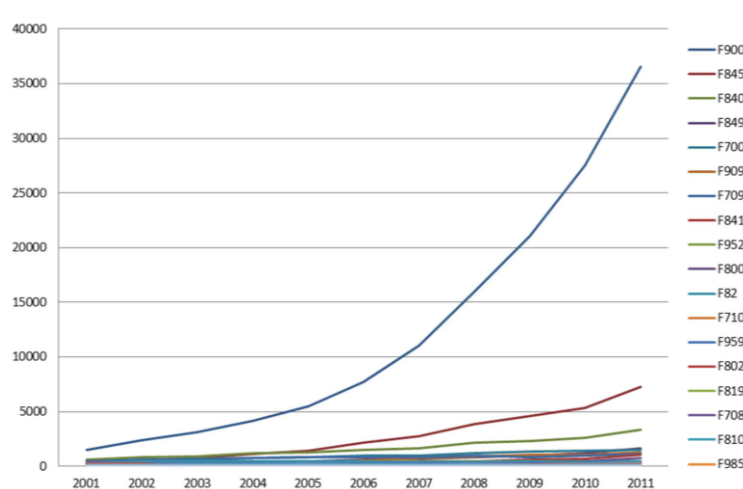

Figure 1. Frequency of diagnoses of ADHD (F900) and other psychiatric disorders in Sweden from 2001 to 2011 (Swedish National Board of Health & Welfare).

Rates of ADHD diagnosis have increased over the past years. In the United States, rates of ADHD diagnosis increased an average of 3% per year from 1997 to 2006 and an average of 5.5% per year from 2003 to 2007. Approximately 9.5% of U.S. children 4-17 years of age (5.4 million) have been diagnosed with ADHD by 2007, according to parent-reports [22], and two thirds of those children received medication for the disorder [23]. These rates reflect a marked increase over the last decade and raise substantial concerns among the public about the increasing number of ADHD diagnosis and medication [24]. A similar trend is also observed in Sweden (Figure 1). However, the increased number of diagnoses may be explained by the improved coverage of medical registers and the increased recognition of the disorder across time, rather than by increased incidences of the disorder itself. Based on a review of prevalence studies and research on the diagnostic process, there does not appear to be sufficient evidence that that ADHD is systematically over-diagnosed [25]. On the other hand, there are also misdiagnoses and underdiagnoses.

### **1.1.3 Persistence**

ADHD has long been considered as a childhood disorder that did not continue beyond adolescence. This idea has been challenged by systematic follow-up studies of children with ADHD, which documented a substantial degree of persistence over time [26-28]. The prevalence of ADHD in adults is estimated to be about 2-4% [17,18], which means that it is one of the most common psychiatric disorders in clinical settings and society at large. The degree of persistence depends largely on the definition of ADHD in adults. Adults must have childhood-onset, persistent and current symptoms of ADHD to be diagnosed with the disorder. DSM-IV-TR [29] added “in partial remission” that can be applied to individuals who have some persistent symptoms and continued clinical impairment, but no longer fulfill the full criteria. Meta-analysis has shown that approximately 15% of children with ADHD continue to meet the full criteria up to 25 years of age, but when including ADHD in partial remission, the rate of persistence is much higher, approximately 65% [28].

Longitudinal studies have shown that inattention symptoms tend to persist across the development to a greater extent than symptoms of hyperactivity and impulsivity, which indicate the predominant symptom features of childhood and adult ADHD may differ [30-32]. Adults with ADHD tend to have impediments in many areas of life, including work, daily activities, social and family relationships and psychological and physical well-being [33]. The substantial societal burden of adult ADHD highlights the importance of increasing our understanding of the disorder and of ways to develop better treatment strategies.

Despite increased interest about adult ADHD [34,35], ADHD is still largely under-diagnosed in adults [36]. Besides the low levels of social and clinical recognition of adult ADHD, the lack of developmentally appropriate diagnostic criteria for ADHD in adults has made diagnoses difficult. The DSM-5 makes a special effort to address adults affected by ADHD to ensure that they are able to get care when they need it [37].

The age of onset criterion has been changed from “symptoms before age 7 years” to “prior to age 12”. The symptom threshold has also been changed to reflect clinically significant ADHD impairment in adults. For an adult diagnosis to be made, the patient only needs to meet five symptoms (instead of six for children) in either of the two symptom domains (inattention and hyperactivity-impulsivity).

#### **1.1.4 Neurobiology**

The developmentally inappropriate levels of inattention and hyperactivity-impulsivity in ADHD patients could reflect a course of brain development that is atypical or typical but delayed. The primary source of evidence supporting the neurodevelopmental basis of ADHD has come from neuroimaging studies. Structural magnetic resonance imaging studies have found that a variety of brain sub-regions are associated with ADHD, including frontal and parietal cortexes, basal ganglia, cerebellum, hippocampus, and corpus callosum [38-40]. The most replicated finding is that ADHD is associated with smaller volumes of dorsolateral prefrontal cortex, cerebellum, and subcortical structures [41,42]. Longitudinal imaging studies have provided evidence that the structural abnormalities observed in children with ADHD may be caused by a delay in structural maturation [43,44]. Functional magnetic resonance imaging measures the activity of brain regions involved in psychological tasks. Meta-analyses of functional imaging studies, that compared ADHD patients to controls, indicate hypo-activation occurs in the brain system (e.g., frontal-subcortical circuits) involved in executive functions [45,46]. Executive functions include neurocognitive processes, such as inhibition, working memory, set-shifting, interference control, planning, and sustained attention [47]. Deficits in executive functions have been implicated in most of the neuropsychological theories about ADHD [48-50].

At the molecular level, evidence from animal and psychopharmacological studies suggests that dopaminergic, adrenergic and possibly serotonergic systems are involved in the pathophysiology of ADHD [51,52]. In general, alterations in any single brain region or neurotransmitter system are unlikely to explain the heterogenetic nature of ADHD. Rather, ADHD is increasingly being recognized as a disorder underlaid by dysfunction in multiple neuronal systems [46,53].

## **1.2 ORIGINS**

### **1.2.1 Genetic risk factors**

For many decades, studies have shown that ADHD runs in families, regardless of the changes in terminology and assessment approaches [54-56]. Family studies have identified two to eightfold increases in the risk of ADHD in first degree relatives of children with ADHD [57]. Because of its strong familial nature, genetically informative studies have been use to separate the genetic and shared environmental effect in the familial aggregation of the disorder.

Twin studies have been used to establish the heritability of ADHD, i.e., the degree to which ADHD is influenced by genetic factors. The twin method relies on the difference

between the within-pair similarities of monozygotic (MZ) twin pairs, who are genetically identical, and dizygotic (DZ) twin pairs, who share on average 50% of their segregating genes [58]. The extent to which MZ twins are more similar than DZ twins can be used to compute heritability (see section 4.1.1). Numerous twin studies have been conducted on childhood ADHD in different countries and cultures, using varied definitions of ADHD. The mean estimate of heritability of ADHD in children has been found to be 0.76 [57], suggesting that genes have a substantial role in the development of ADHD. Adoption studies of ADHD also demonstrated a genetic etiology, by showing that the biological relatives of ADHD children have a greater risk of ADHD than the adoptive (i.e., non-biological) relatives of adopted ADHD children [57].

In contrast to the consistently high heritability estimate of ADHD in children, the few twin studies that have investigated ADHD in adults, which all relied on self-ratings, found lower heritability, with estimates between 30% and 40% [59-62]. However, it is still unclear whether these self-report studies indicate a true difference in the heritability of childhood and adult ADHD, or they reflect a rater bias [63].

Given the high heritability of ADHD, considerable efforts have been, and still are being, made to search for specific susceptibility genes for ADHD. Two main approaches have been used: 1) candidate gene studies, which are often considered as “hypothesis-driven”, and test one or more genetic variants that might be biologically relevant; 2) genome-wide association studies (GWAS), which are “hypothesis-free” and search the whole genome for common and rare genetic variants. Within the large and conflicting literature on candidate gene associations for ADHD, a small number have been shown significant associations withstanding replication and meta-analysis, including genes involved in the dopaminergic pathway (*DAT1*, *DRD4*, *DRD5*) and others (*5HTT*, *HTR1B*, and *SNAP2*) [57,64]. The few GWAS on ADHD that have been performed to date have failed to identify any common genetic variant that reaches the genome-wide significance level ( $p=5\times 10^{-8}$ ; the statistical threshold is set this high to correct multiple testing) [65-67]. Recent findings suggest that rare chromosomal deletions and duplications, known as copy number variants, are associated with neurodevelopmental disorders, including ADHD [68,69]. It is now generally accepted that we should not expect to find a single or even a few genes responsible for ADHD, since most psychiatric disorders involve many genetic variants (and environmental factors) that only make small contributions to their etiology [70].

## 1.2.2 Environmental risk factors

Many environmental factors have been proposed as risk factors for ADHD, including pre- and perinatal factors (e.g., maternal smoking during pregnancy [SDP], low birth weight, and young maternal age), environmental toxins (e.g., lead and polychlorinated biphenyls), dietary factors (e.g., food additives), and psychosocial adversity (e.g., low income and parent-child conflict) [71,72]. However, many of these studies simply measured the associations between potential risk factor and ADHD, and it has been difficult to determine which risk factors are causal [73-75]. As correlation does not

necessarily equal causation, extreme caution is needed to interpret associations from observational studies. Most putative environmental factors (e.g., SDP, young maternal age) are not randomly distributed and could arise because of selection factors (e.g., low family income) [76], and these selection factors (or usually called “confounder”) may account for observed association between both putative environmental factors and ADHD. Without a clear understanding of their causal effects, interventions could target the wrong factors, and ignore potentially important risk factors.

While a randomized controlled trial (RCT) is considered as the gold standard for evaluating the causal effect of modifiable environmental factors, it is not always feasible or ethical. One appealing alternative is quasi-experimental design that can tease apart co-occurring risk mechanisms and account for unmeasured genetic and environmental confounds [77-79] (see section 4.1.2). One of the most studied prenatal risk factors for ADHD is SDP [80]. It is theoretically compelling as a causal risk factor because nicotinic receptors modulate dopaminergic activity, which is believed to be involved in the pathophysiology of ADHD. However, this causal hypothesis has been challenged by growing evidence from studies using genetically-informative designs [81,82]. By comparing siblings discordantly exposed to SDP, these studies found that the association between SDP and offspring ADHD is attenuated towards null, which suggest this association is primarily explained by familial (genetic or environmental) confounding.

### **1.3 CONSEQUENCES**

ADHD predicts many clinically meaningful outcomes. Research has shown that ADHD is associated with a high risk of comorbidity with other psychiatric disorders [83-85]. ADHD is also associated with functional impairments such as school dysfunction, peer problems, family conflict, poor occupational performance, accidental injuries, anti-social behavior, and traffic accidents [33,86], all of which exert an enormous burden on the patients, families and society [87,88].

#### **1.3.1 Psychiatric comorbidity**

ADHD exhibits a high level of comorbidity with a wide variety of other psychiatric and developmental disorders. In children and adolescents, psychiatric disorders comorbid with ADHD include oppositional defiant disorder (ODD), conduct disorder (CD), mood disorder (both unipolar and bipolar), anxiety disorder, and substance use disorder (SUD) [3,89]. CD/ODD is the most commonly comorbid condition of childhood ADHD, and has been found to co-occur in 30% to 50% of cases [85]. There are also well-established associations between ADHD and intellectual disability, specific learning and developmental problems, and autistic spectrum disorders [90-93].

Much of the early research on comorbidity, however, is limited by its reliance on correlational and cross-sectional designs. For example, the cumulative results of retrospective studies of adults and prospective studies of children indicate that children and adolescents with ADHD are at increased risk of SUD [94-96]. However, it has long



been controversial whether ADHD is an independent risk factor for SUD, or the risk is due to comorbid CD. Moreover, results from family and twin studies suggest there might be a common genetic component that explains the overlap between ADHD and its comorbid disorders [97-99]. Longitudinal studies with a genetically informative sample may provide insight into the potential mechanisms that explain how ADHD is associated with other comorbid problems.

### **1.3.2 Functional impairment**

Individuals with ADHD are affected by the disorder throughout their lifetimes. Children diagnosed with ADHD have been shown to be more likely to experience academic failure than their non-ADHD peers; they are more likely to have poor grades, poor reading and math test scores, or grade retention, and are less likely to graduate [100,101]. Children with ADHD have also been shown to have difficulties in family and peer relationships [102], and have a high predisposition for accidental injury [103,104].

For those adolescents and adults with persistent ADHD, educational difficulties continue, and problems in the areas of occupational and social activity, driving, and sexual relationships emerge. Individuals with ADHD have been shown to be more likely to be unemployed and have lower income compared to controls [105]. ADHD may interfere with driving competence, predisposing those with ADHD to impaired driving performance and increased risk for adverse driving outcomes [106,107]. Adolescents with ADHD begin having sexual intercourse early, and have difficulties in maintaining partnership [33].

Although the ADHD-related impairments have been well-documented in the past literatures, some methodological shortcomings (e.g., small sample sizes, absence of females, inadequate controls, and referral bias) raise uncertainty about the magnitude of these associations [107,108]. In addition, studies using more recent data are needed in lights of the increasing diagnoses of ADHD [22].

## **1.4 TREATMENT OF ADHD**

The treatment of ADHD involves two major domains: non-pharmacological treatment and pharmacological treatment.

Non-pharmacological treatments include different forms of psychosocial interventions. Behavior modification (e.g., clinical behavior therapy, contingency management) which uses reward and response cost to increase desired behaviors and decrease undesirable behaviors, has been shown to effectively improve the functioning of children with ADHD [109,110]. Behavior modification typically involves working with parents and teachers to program behavioral contingencies into the child's home, school, and recreational environments. Cognitive-behavioral therapy has shown positive results in adults with ADHD [111]. Non-pharmacological treatments are used by themselves or in combination with pharmacological treatment.

The Swedish national guidelines for medication of ADHD, issued by the Swedish National Board of Health and Welfare in 2002, stated that pharmacological treatment should be reserved for cases in which other supportive interventions have failed. In many other countries, however, pharmacological treatment is the mainstay for treatment of children, adolescents and adults with ADHD [112]. Stimulants are the front-line medications for ADHD, which include methylphenidate (Ritalin, Concerta and others), dexamethylphenidate (Dexedrine and others), mixed amphetamine salts (Adderall), and lisdexamfetamine (Vyvanse). Non-stimulant medications (e.g., atomoxetine) have also been used to treat ADHD, although their efficacy seems to be slightly lower than that of stimulants [113,114]. An important development of ADHD medication is the formulation of extended-release stimulants, which greatly reduce untoward peak adverse effect and eliminate afternoon rebound [112].

Findings from RCTs indicate that ADHD medications have beneficial short-term effects on the core symptoms of ADHD [51,115-120], and suggest they may contribute to improvements in multiple related domains [121]. A recent population-based study also suggested reductions in criminality while under medication [122]. However, the effect of ADHD medication is still not adequately studied in many other important areas, such as transport accidents.

The possible beneficial effects of medication on short-term behavior have to be carefully weighed against potential adverse effects [123]. The use of stimulant medication for ADHD treatment has been one of the most controversial areas in child psychiatry. So far, there is no conclusive evidence that careful use of ADHD medication is harmful. However, concerns have been expressed over about the long-term effects of ADHD medication on cardiovascular risk, growth delay, suicide, and the development of substance abuse [124].

One big threat to observational studies of the effect of medication is confounding by indication [125]. It is possible that patients receiving medication might be different from non-medicated patients in a number of ways, such as symptom severity or comorbid disorders. Therefore the observed effect of medication might be biased by these (confounding) factors. In observational studies, it is rarely possible to measure all such potential confounding factors. Ideally, the benefits and risks of ADHD medication should be evaluated by RCTs. However, an RCT on the long-term effects of ADHD medication is unlikely to be feasible because of practical and ethical reasons. Another common problem for ADHD medication is poor medication adherence [126]. This problem affects both observation studies and RCTs, and most of the research should be interpreted as intention to treat analyses. On the other hand, treatment discontinuation also provides opportunities to study the effect of medication using novel designs based on observational data [122].

It should be noted that the rate of ADHD prescription rates has increased substantially in Sweden [127] and other countries [128,129]. The use of ADHD medication in

Sweden increased 34% per year from 2006 to 2009, on average [127]. Therefore, there is a critical need to accurately evaluate the specific benefits and risks of ADHD medication, with population-based samples and designs that can explore rare and serious outcomes [130,131].

## **1.5 SPECIFIC RESEARCH QUESTIONS**

### **1.5.1 Heritability of ADHD throughout development**

Twin studies based on parent and teacher ratings yield high heritability estimates for ADHD symptoms in childhood and adolescence, usually in the range of 70% to 80% [57]. In contrast, the few twin studies that have investigated ADHD in adults, which relied on self-ratings, have found lower heritability estimates, ranging between 30% and 40% [59-62]. However, because there are no published informant or cross-informant data on adult twins, it is not clear whether results of these studies indicate a true difference in the heritability of ADHD in adults compared with children or whether they reflect the use of self-ratings in contrast to informant data [63,132]. Family studies, showing a high familial loading on ADHD in adults [133], support the latter explanation.

Most previous twin studies have used cross-sectional data to estimate heritability at different ages and are therefore unable to distinguish stable genetic risk factors that influence the disorder over time from genetic factors that emerge during development. The few longitudinal twin studies indicated that both stable and dynamic genetic factors influenced the development of ADHD [134-137], unfortunately, none of these studies followed the twins into adulthood. Knowledge about the developmental structure of genetic risk factors for ADHD, from childhood to adulthood, would help to clarify the nature of the etiological links between ADHD in children and adults.

In Study I, we applied a longitudinal design with multi-informant data, to explore the relative contribution of genetic and environmental influences on attention problems (an index of ADHD) from childhood to early adulthood. The use of multi-informant data allowed us to explore whether previous reports of low heritability for ADHD in adults are best explained by rater effects or developmental effects. The longitudinal design allowed us to examine the continuity and change in genetic and environmental risk factors throughout development.

### **1.5.2 Young maternal age and offspring ADHD**

An important, but less explored, risk factor for ADHD is young maternal age (the age of the mother when giving birth). Teenage childbearing is recognized as an important public health concern worldwide, and it is associated with a wide range of negative developmental outcomes for offspring [138], in particular antisocial behaviors [139,140]. Despite the high comorbidity between ADHD and antisocial behaviors [141,142], few studies have examined the association between young maternal age and offspring ADHD.

Two studies have shown that young maternal age is associated with increased risk for ADHD [143,144]. However, both of the studies reported only correlations, and the mechanisms underlying this observed association are poorly understood. One important issue, when studying maternal age, is to distinguish between maternal age at current birth (MACB) and maternal age at first birth (MAFB); i.e., whether maternal age at childbearing have offspring-specific effects, or offspring-shared effects.

If all children born to young mothers have a similar increased risk of ADHD, then this suggests that maternal age at childbearing has offspring-shared effects, and MAFB represents a more relevant index than MACB. MAFB could be causally associated with ADHD in all offspring. Early childbearing may disrupt the developmental trajectory of young mothers, leading to poverty, poor education, and ineffective parenting [145], which increase the risk for ADHD in offspring. Alternatively, MAFB might not be causally associated with offspring ADHD. Rather it may be a marker for genetic or environmental selection factors that are causally associated with both maternal age and offspring ADHD. Putative environmental risk factors (e.g., young maternal age) could be influenced by genetic factors, which would be transmitted from parents to their offspring and account for the poor outcome in offspring, a phenomenon known as passive gene-environmental correlation (rGE) [146,147].

Study II attempted to explore the mechanism underlying the association between early maternal age at childbearing and offspring ADHD. The study used quasi-experimental designs to try to understand how early life circumstances affect child development.

### **1.5.3 ADHD and early-onset substance use**

Research has documented that children with ADHD are at increased risk of SUD [94-96]. However, the mechanism underlying this association is still unclear because of several issues. First, it is unclear whether ADHD is an independent risk factor for SUD, or the association reflects its comorbidity with CD [148]. Second, it is unclear which symptom dimension of ADHD (inattention [IN] or hyperactivity-impulsivity [HI]) predicts SUD. Some studies suggested that IN predicts SUD [96,149,150], which is in line with the self-medication hypothesis that patients with ADHD would use nicotine to compensate attention and executive deficits [151-153]. In contrast, a population-based prospective study found HI, independent of inattention and CD, predicts early-onset tobacco, alcohol, and illicit drug use. Third, it is unclear to what extent the observed association is influenced by common genetic and environmental contributions. Both ADHD [57] and substance use [154] are heritable, and the association between ADHD and substance use could be explained by common genetic influences [98,99].

In Study III, we tried to address these issues by investigating the longitudinal relationship between the two symptom dimensions of ADHD and early-onset substance use in a large population-based twin sample, taking CD into account. Early-onset substance use is an important, but less studied, problem, because early adolescence is a sensitive developmental period for exposure to substances [154], and because early-

onset substance use is a strong predictor of development of SUD and other health problems [155,156].

#### **1.5.4 ADHD, transport accidents, and the effect of medication**

According to report of the World Health Organization (WHO), approximately 1.3 million individuals are killed each year by traffic accidents, and 50 million are injured or disabled [157]. An emerging literature has documented an association between ADHD and transport accidents [107,108,158-160]. However, small sample sizes, lack of females in the studies, absence of objective measures, inadequate controls, and referral bias raise uncertainty about the reported magnitude of the associations [106, 109].

A few studies have explored whether ADHD medication improves driving ability in virtual-reality driving simulators [107,159,161], however, the extent to which these effects generalize to real-world situations is unclear. Because decisions regarding the prescription of ADHD medication need to consider the effect sizes of the benefits and risks of medication at the population level [123,162], a population-based prospective study with measures of transport accidents in real life (i.e., injuries and deaths) is needed.

In Study IV, we used data from population-based registers in Sweden to assess two research questions: First, what is the magnitude of the association between ADHD and serious transport accidents (injuries and deaths); second, to what extent ADHD medication influences the risk of transport accidents among ADHD patients.

#### **1.5.5 ADHD medication and risk of substance abuse**

There have been concerns over the long-term effects of medication on the development of substance abuse [163,164].

It is well-established that ADHD is associated with an increased risk for substance abuse [95,165], and this comorbidity has led to the hypothesis that this risk is mediated, at least in part by exposure to stimulant medication. This hypothesis is grounded by findings from animal studies that animals exposed to stimulants become “sensitized”, a phenomenon of increased response to an addictive substance after repeated exposure [166,167]. Although many studies seem to find no or possibly protective effects of ADHD medication on substance use [168-172], their sample sizes were limited. More evidence is critical to help ADHD patients, and their families and clinicians to make treatment decisions.

In Study IV, we used data from population-based registers in Sweden to test the hypothesis that stimulant ADHD medication is associated with an increased risk for long-term substance abuse.

## 2 AIMS

The general aim of this thesis was to investigate how genetic and environmental factors contribute to the development of ADHD, as well as to investigate the consequences of ADHD and potential influences of ADHD medication.

The specific aims were:

- To explore the relative contribution of genetic and environmental influences on symptoms of attention problems from childhood to early adulthood.
- To explore the mechanisms that underlying the association between early maternal age at childbearing and offspring ADHD, using a genetically-informative design.
- To investigate how the two symptom dimensions of ADHD (hyperactivity-impulsivity and inattention) are associated with early-onset substance use, and the extent to which the association is influenced by genetic and environmental factors.
- To estimate the association between ADHD and the risk of serious transport accidents, and to explore the extent to which ADHD medication influences this risk among ADHD patients.
- To verify whether stimulant ADHD medication is associated with risk for long-term substance abuse.

## **3 STUDY SAMPLES**

### **3.1 THE SWEDISH TWIN STUDY OF CHILD AND ADOLESCENT DEVELOPMENT**

#### **3.1.1 Sample and Response Rate**

The data used in Study I and Study III comes from the Twin study of CHild and Adolescent Development (TCHAD) [173]. The target sample consisted of all the 1,480 twin pairs born in Sweden between May 1985 and December 1986 who were alive and residing in Sweden in 1994. The twins were identified through the population-based Swedish Twin Registry (STR) [174]. The twins and their parents had been contacted via questionnaires mailed in four different waves: wave 1 in 1994 (childhood, ages 8–9); wave 2 in 1999 (early adolescence, ages 13–14); wave 3 in 2002 (late adolescence, ages 16–17); and wave 4 in 2005 (early adulthood, ages 19–20).

The response rates for the parent questionnaires were 75% (n=1,109) in wave 1, 73% (n=1,063) in wave 2, 74% (n=1,067) in wave 3. In wave 4, both parents were approached separately, and responses were obtained from at least 1 of the parents for 1,158 twins. A majority of the parent-reported information was supplied by the twins' mothers (75%-90%). The response rates for the twin questionnaires were 78% (n=2,236) in wave 2, 82% (n=2,369) in wave 3, and 59% (n=1,705) in wave 4.

#### **3.1.2 Zygosity determination**

Zygosity was assessed by DNA testing. The twins' DNA was extracted from saliva samples using an Ora-Gene DNA self-collection kit (DNA Genotek Inc). For twins without a DNA sample, zygosity was determined based on an algorithm derived from discriminant analyses of twins' and parents' responses to validated zygosity questionnaires [173]. In cases in which the assignments were questionable (n=100, 3.4%), the zygosity was set to unknown, and the twins were excluded from the analyses. It should be noted that in earlier reports from the TCHAD study, other algorithms were used for zygosity classification. However, we have used the best available zygosity diagnose at each time point, and the variations between the different methods are small and of minor importance.

#### **3.1.3 Measures**

TCHAD is a longitudinal study of how genes and environments contribute to the development of health and behavioral problems from childhood to adulthood. Major domains of measures (in different waves) included socio-demographic factors, physical health, competence, behavior, personality, externalizing/internalizing behavior and symptoms, life events and relationships.

### 3.1.3.1 *DSM-based symptoms of ADHD*

A checklist of ADHD symptoms, with 21-24 items based on DSM, was completed by parents at waves 1, 2, and 3. The parents were asked to mark (yes or no) any inattention (IN) or hyperactivity-impulsivity (HI) symptom that persisted for at least six months. Because of changes in the DSM during the follow-up period, the complete set of all 18 DSM-IV symptoms were not included in each wave. In Study III, we used parent-rated ADHD symptoms when the twins were 8 to 9 and 13-14 years old. In wave 1, parent rated ADHD symptoms via a checklist of 14 items based on the DSM-IV (6 IN symptoms and 8 HI symptoms) [134]. In wave 2, the checklist included 17 items based on the DSM-IV (8 IN symptoms and 9 HI symptoms). The internal consistency (alpha reliability) for IN was 0.78 in wave 1 and 0.74 in wave 2. The alpha reliability for HI was estimated as 0.77 in both waves. Our ADHD instrument has not been formally validated as a measure, but has been used in several prior epidemiological studies by our research group. Results from these studies were consistent with well-established findings in the ADHD literature [32,134,175,176].

### 3.1.3.2 *Child Behavior Checklist/Youth Self-report*

Parents completed the Child Behavior Checklist (CBCL) [177] when the twins were 8 to 17 years old, and the Adult Behavior Checklist (ABCL) [178] when the twins were 19 to 20 years old. The twins completed the Youth Self-Report form (YSR) [179] and the Adult Self-Report form (ASR) [178] at the corresponding ages. The CBCL, YSR, ABCL, and ASR are standardized questionnaires for parents and twins to rate the frequency and intensity of behavioral and emotional problems exhibited by the twins during the past 6 months. All items were scored on a 3-point scale (0=not true; 1=sometimes true; and 2=often true). The YSR consists of the same items as those in the CBCL. The ABCL and ASR consist of similar or developmentally appropriate counterparts of items used in the CBCL and YSR.

In Study I, we used the parents' ratings and the twins' self-ratings of Attention Problems (AP) scale at ages 8 to 9, 13 to 14, 16 to 17, and 19 to 20 years. The AP scale assesses problems related both to inattention and hyperactivity-impulsivity and has been found to predict ADHD status [180-182]. We therefore consider the AP scale to be a measure of ADHD symptoms.

In Study III, we created conduct problem behavior (CPB) sum scores based on the 15 items included in the CBCL/6-18-DSM-oriented conduct problems scale. The internal consistency (alpha reliability) was 0.80 at both waves. The CBCL DSM-oriented scales were initially constructed through agreements in experts' ratings regarding the consistency between CBCL items and specific DSM-IV diagnostic criteria [183].

The psychometric properties of these scales have been examined in both population-based and clinical samples, presenting good reliability, as well as convergent and discriminative validity [177-179,183-185].



### **3.1.4 Representativeness of the sample**

Previous attrition analyses across the waves of TCHAD found no significant differences in sex ratio, family social economic status, or the number of ADHD symptoms in wave 1 when comparing participants and non-participants in wave 2 [175]. Furthermore, follow-back analyses revealed that there were no significant differences in wave 2 data between participants and nonparticipants in wave 1 [186]. However, there is some evidence of selective attrition in wave 4; attrition rates at age 19-20 years were higher for individuals with higher levels of childhood ADHD symptoms, and for boys. Thus, it is possible that the variation of ADHD at extreme level is truncated and the results may not be generalizable to cases with the most extreme cases of ADHD. However, it is unlikely that attrition biased the genetic or environmental parameter estimates, because the intra-class correlations at baseline (age 8-9 years) were similar among the longitudinal responders and non-responders.

## **3.2 SWEDISH NATIONAL REGISTERS**

The data used in Study II, Study IV and Study V come from linkage of national population-based registers in Sweden, with unique personal identification numbers, which enabled accurate linkage [187].

### **3.2.1 National Patient Register**

The National Patient Register (NPR), kept by the National Board of Health and Welfare, provides data on all hospital admissions in Sweden. Every record has a discharge date, a primary discharge diagnosis and up to eight secondary diagnoses assigned by the treating medical doctor according to the ICD: ICD-8 for 1969-1986, ICD-9 for 1987-1996 and ICD-10 from 1997 [8]. The NPR has national coverage of psychiatric in-patient care since 1973, and information on psychiatric out-patient care since 2001. Information from the NPR was used to identify ADHD cases (the outcome in Study II, study population in Study IV and V), emergency hospital care due to transport accidents (the outcome in Study IV), hospital visits due to psychoactive substance use (the outcome in Study V), and other disease diagnosis used as covariates in the different studies.

### **3.2.2 Multi-Generation Register**

The Multi-Generation Register (MGR), held by Statistics Sweden, contains information about biological and adoptive relationships for more than 13 million individuals born 1932-2009 and registered as living in Sweden at any time during 1961-2009 [188]. The register is part of the Total Population Register (TPR), which collects information from the national registration records maintained by the National Tax Board. For each target individual, the register includes information on the identification number of biological parents and adoptive parents, if appropriate. The registry also includes date of birth information for each individual. Information from the MGR was used to identify different types of family structures used in Study II, including siblings and children of siblings/twins.

### **3.2.3 Medical Birth Register**

The Medical Birth Register (MBR), kept by the National Board of Health and Welfare, includes data on all pregnancy outcomes and complications in Sweden from 1973 onwards. It includes data on newborn children and their mothers from more than 99% of births in Sweden [189]. The register includes detailed demographic and pregnancy information, including maternal age at childbirth, maternal living situation, maternal smoking during pregnancy, birth order of the child, the infant's physical attributes at birth, pregnancy complications, and delivery complications. Information from the MBR was used to obtain maternal age at childbirth (the exposure in Study II), and other covariates in Study II.

### **3.2.4 Prescribed Drug Register**

The Prescribed Drug Register (PDR), also kept by the National Board of Health and Welfare, includes data on all prescribed drugs dispensed at pharmacies in Sweden. It contains information regarding drug identity, according to the Anatomical Therapeutic Chemical classification system (ATC), quantity and dosage of the prescribed drug, date of prescription/dispensing, and specific patient information (gender, age and residential area). The register has covered the entire population of Sweden since July 2005, and the identity of the patients is available for over 99.7% of the population [190]. Information from the PDR was mainly used to identify use of ADHD medication (the exposure in Study IV and V, ATC code: N06BA04, N06BA01, N06BA02, and N06BA09).

### **3.2.5 Causes of Death Register**

The Cause of Death Register (CoD), also kept by the National Board of Health and Welfare, includes mandatorily reported information from death certificates for all deceased individuals. It contains data on the principal and contributing causes of death, coded according to the ICD. The register was established in 1952, and it contains complete information on causes of death since 1961. Information from the CoD was used to identify death resulting from transport accidents (the outcome in Study IV), death resulting from psychoactive substance use (the outcome in Study V), and used as end points in all follow-ups.

Data from the Migration Register, the Crime Register and the Integrated Database for Labor Market Research were also used in different studies to provide information on migration, crime records and socio-demographic variables (e.g., civil, employment, and education status).

## 4 STUDY DESIGNS AND METHODS

### 4.1 GENERAL METHODS

#### 4.1.1 Twin methodology

The pioneering study on twins dates back to 1875, when Sir Francis Galton published an article titled “The history of twins, as a criterion of the relative powers of nature and nurture” [191]. Since then, the twin methodology has been widely used as a ‘natural experiment’ in research to disentangle and to quantify the contributions of genetic and environmental effects on human complex traits. The twin method relies on the different within-pair similarities between MZ twin pairs, who are genetically identical, and DZ twin pairs, who share 50% of their segregating genes, on average. By comparing the within-pair similarities, one can infer the presence of genetic and environmental influences on a trait. A genetic influence is indicated if twin similarity is greater among MZ than DZ twin pairs.

In the 1970s, research began to employ variance partitioning using maximum likelihood methods [192]. From biometric genetic theory, it is possible to write structural equations that relate the observed traits of twins to their underlying genetic and environmental influences [193]. In the classic twin model, the variance of an observed phenotype can be decomposed into three variance components: additive genetic factors (A), shared environmental factors (C), and non-shared environmental factors (E). Shared environmental factors are non-genetic influences that make the twins similar, and non-shared environmental factors refer to non-genetic influences that make the twins different. The contribution of these ‘latent’ factors can be estimated by comparing the similarity between MZ twins and DZ twins. Figure 2 illustrates the classic ACE model for analyzing twin data.

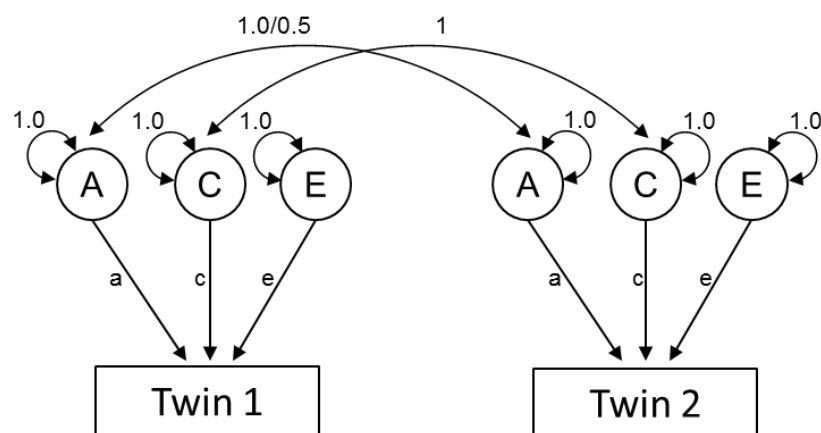

Figure 2. Classic ACE model for analyzing twin data.

The genetic correlation between twin pairs is 1 for MZ twins, and 0.5 for same sex DZ twins. The shared environmental correlation is 1 for both MZ and DZ twins, under the

equal environment assumption. The non-shared environmental correlation is 0, by definition.

Heritability is defined as the proportion of phenotypic variance among individuals attributable to genetic factors [58]. It is important to note that heritability does not refer to the genetic composition of any individual. Rather, it refers to the genetic contribution to the difference between individuals in a defined population.

During the past decade, twin research has moved from simple univariate analyses to more complex longitudinal and multivariate analyses. In Study I, multivariate analysis of longitudinal data was used to study the development of ADHD over time. In Study III, multivariate analysis was used to explore the causes of comorbidity between disorders. By including additional family types, it was also possible to study the intergeneration transmission (Study II).

The structural equation modeling (SEM) packages Mx [194] and OpenMx in R [195] were used to perform full information maximum-likelihood model-fitting with raw data. A liability threshold model was applied to categorical variables, which assumes that the ordered categories reflect an imprecise measurement of an underlying normal distribution of liability [193]. Traditionally, goodness-of-fit of models are assessed by likelihood ratio tests. More recently, the Bayesian information criterion, which measures model fit relative to parsimony, has been widely used for multivariate behavior genetic models [196].

#### **4.1.2 Quasi-experimental designs**

Determination of the causal connections between modifiable risk factors and outcomes is one of the key challenges in the field of developmental psychopathology [76]. Tests of causal hypotheses often require prospective longitudinal studies in which reverse causation is not possible. In addition, tests of causal hypotheses must be cautious about the possibility that genetic and environmental selection factors account for non-random exposure of environmental risk factor and, thereby, confound the associations between exposure and outcomes [73,146]. Quasi-experimental designs can be used to test causal hypotheses by ruling out plausible alternative explanations.

##### *4.1.2.1 Genetically informative design*

The comparison of differentially exposed full siblings provides a rigorous test of causal hypotheses about early risk factors because the design can rule out unmeasured confounds that limit the comparison of unrelated individuals, including all environmental influences that are shared by siblings within nuclear families and all genetic factors [197]. Sibling comparisons rule out confounded genetic risk transmitted by mothers (shared genetic liability due to passive rGE) because the process of meiosis randomly distributes genes across siblings. Whereas the comparison of siblings controls for environmental factors shared by all siblings in a nuclear family, the comparison of differentially exposed cousins controls for environmental factors that influence all

offspring in an extended family. Full cousins (offspring of full siblings) share 12.5% of their genetic makeup. Thus, the comparison of full siblings also partially controls some genetic selection factors. This approach does not control for confounds as well as the comparison of full siblings, but is useful for studying familial-level factors (e.g., maternal age at first childbirth in Study II). In addition to sibling comparisons and cousin comparisons, comparisons of half-siblings, half-cousins, and children of twins provide opportunities to replicate the findings, and to test many of the assumptions inherent in each design. The different groups of relatives used in different designs are shown in Figure 3.

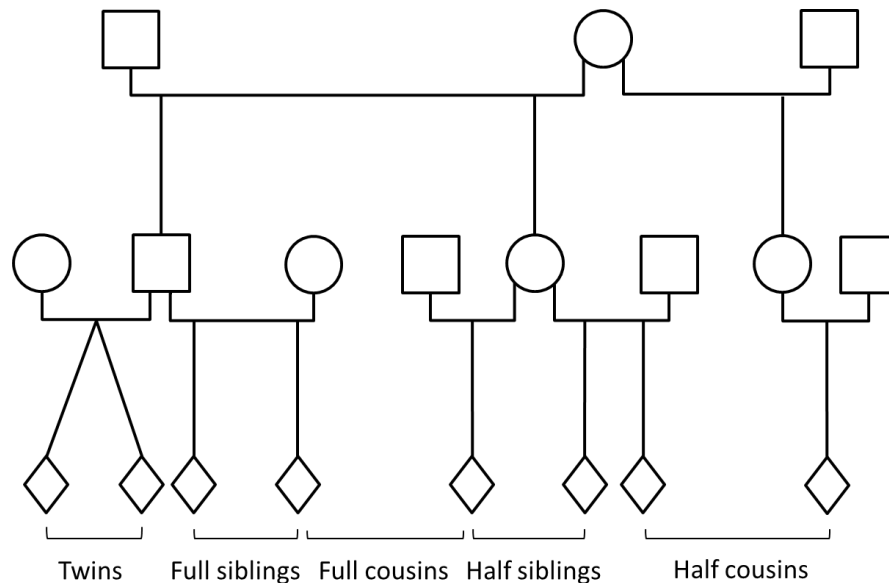

Figure 3. Schematic of groups of relatives used in the studies.

Sibling/cousin comparisons are performed by fitting fixed-effect models [198], under certain assumptions [199]. If an environmental risk is causally associated with an outcome, then the association should remain in sibling/cousin comparisons. If the association attenuates or disappears, this suggests that the association between environmental the risk factor and the outcome is, at least partly, due to unmeasured genetic or environmental confounding.

#### 4.1.2.2 *Time-series within-individual design*

Time-series within-individual analysis represents another powerful quasi-experimental design that can be used to study exposures that change over time. In such design, individual serves as his or her own control, and the risk of outcome is compared between exposed periods of time (e.g., treatment) and unexposed periods (e.g., no treatment). As such, the within-individual estimate automatically adjusts for confounding by all unmeasured covariates that are constant within each individual during follow-up (e.g. genetic predisposition and early environments).

This is a useful approach to study the effects of medication, especially when RCTs are not feasible. In Study IV and V, we used this approach to study the effect of ADHD medication on concomitant transport accidents and substance abuse. The use of ADHD medication was treated as a time-varying exposure. Within-individual analyses were performed using stratified Cox regression [198], with each individual entering as a separate stratum.

## 4.2 STUDY I

Study I was based on data from TCHAD sample. Parent ratings and twin self-ratings of AP were measured at ages 8 to 9, 13 to 14, 16 to 17, and 19 to 20 years. Because item performance could vary by rater, sex, or age, we created factor scores of AP separately for each combination of these factors (e.g., parent ratings of boys at age 8-9 years) [200]. Factor loadings were calculated for each item in the program Mplus [201], using a robust weighted least squares estimator.

The relative contribution of genetic and environmental influences on symptoms of AP from childhood to early adulthood was estimated using longitudinal SEM with multiple informants (Figure 4). Both parent- and self-ratings were used as indicators for the latent factors of AP ( $AP_1$  to  $AP_4$ ). The paths  $\lambda_p$  and  $\lambda_s$  reflect the degree to which parent ratings and self-ratings of AP represent the latent AP factors. The genetic and environmental influences on  $AP_1$  to  $AP_4$  are modeled by Cholesky decomposition. The factor structure depicted by latent factors  $F_1$  through  $F_4$  is implemented for the three sources of variance A, C and E. This developmentally informative approach divides genetic risk of  $AP_1$  to  $AP_4$  into four factors ( $F_1$ – $F_4$ ). The model also contains two rater-specific common factors for parent ratings ( $F_p$ ) and self-ratings ( $F_s$ ). These factors allow the model to estimate the genetic and environmental influences on the ratings that are unique to the parents or the children. The remaining part of the phenotypic variance is modeled as rater-specific error effects ( $R_{p1}$ – $R_{s4}$ ).

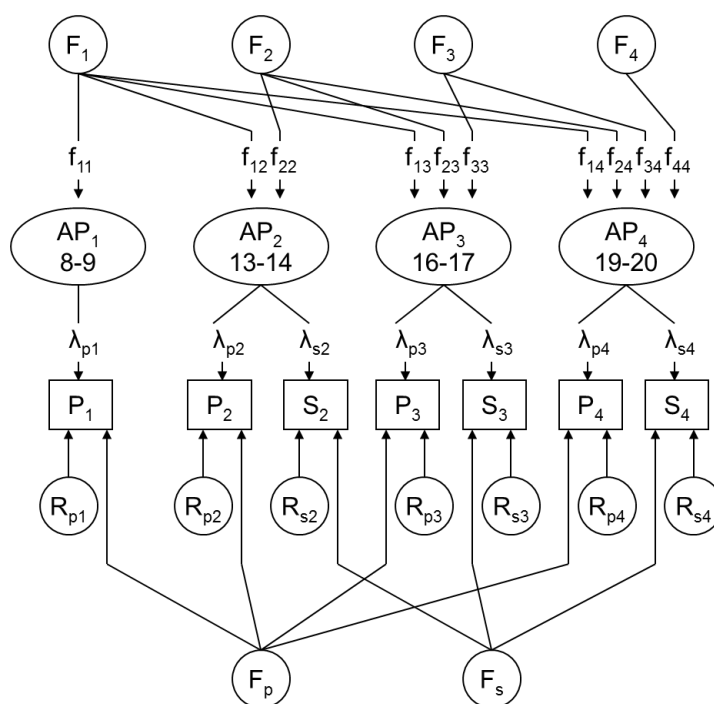

Figure 4. A longitudinal twin model with multiple informants for Attention Problems.

### **4.3 STUDY II**

The association between maternal age at childbirth and offspring's ADHD was studied using genetically-informative data from Swedish national registries. We studied a cohort of children born in Sweden between 1988 and 2003, consisting of 1,640,694 newborn children identified from the MBR. We excluded those children who had severe congenital malformations ( $n = 59,390$ ), who were from multiple births or still-born, who died or emigrated before age 3 or year 2001, and who received an ADHD diagnosis before age 3. The final sample included 1,495,543 eligible individuals (91.2% of the targeted population), which were offspring of 896,389 mothers. Among the full sample, we identified 988,625 full siblings from 443,555 mothers. We further identified children of full sister mothers, maternal or paternal half-sister mothers, MZ or DZ twin mothers.

Maternal age at current birth (MACB) was obtained from the MBR. By linking to the MGR, we also obtained maternal age at first birth (MAFB) for each mother. Since most studies have focused on the distinction between teenage and adult childbearing [138], we used this binary classification to be consistent with previous research. The binary variable of MACB / MAFB was defined as teenage childbearing if the mother was less than 20 years old at current/first child birth, and adult childbearing if the mother was 20 years of age or older. Children who were diagnosed with ADHD, according to the NPR or treated with ADHD medication, according to the PDR, were identified as ADHD cases. In total, we identified 30,674 children with ADHD from these two registers, and the date of diagnosis was defined as the date of first record in any registers.

The extent to which MACB or MAFB is associated with offspring ADHD was explored using three models. Cox regression was used to deal with the right-censored outcome measure. Model 1 examined the population-wide association between MACB and offspring ADHD. Model 2 examined the population-wide association between MACB and offspring ADHD, controlling for MAFB. Model 3 tested the effect of MACB versus MAFB using sibling comparison (see section 4.1.2.1). The association between MAFB and ADHD in offspring was explored using two models. Model 4 examined the population-wide association between MAFB and offspring ADHD. Model 5 estimated the association between MAFB and offspring ADHD using cousin comparisons. To quantify the magnitude of the different processes explaining the observed association between MAFB and offspring ADHD, we used a children of siblings (CoS) model -- a SEM with multiple groups of relatives.

### **4.4 STUDY III**

Study III used data from the TCHAD sample. We used parent reports of ADHD symptoms and CPB (index for CD) from wave 1 and wave 2, and self-report of substance use from wave 2. Substance use at age 13 -14 was assessed using self-reports, which were adapted from the Finnish longitudinal study of adolescent twins [202]. The measures were categorized into three levels for tobacco and alcohol use ("never", "sometimes", and "often" use), and two levels for illicit drug use ("never"

and “ever” use). Importantly, there was no item overlap between these measures (ADHD, CPB and substance use).

We used multinomial logistic regression to investigate the association between inattention and hyperactivity-impulsivity symptoms in childhood and substance use in early adolescence. The “never use” category of substance use was used as a reference group in all multinomial logistic regression models. Odds ratios (OR) with 95% confidence intervals (CI) were estimated using generalized estimating equations models, which allowed us to account for the dependent nature of the twin observations. A bivariate correlated factors model (Figure 5) was used to estimate the genetic correlation ( $r_g$ ), the shared environment correlation ( $r_c$ ), and the non-shared environment correlation ( $r_e$ ) between ADHD symptoms and substance use.

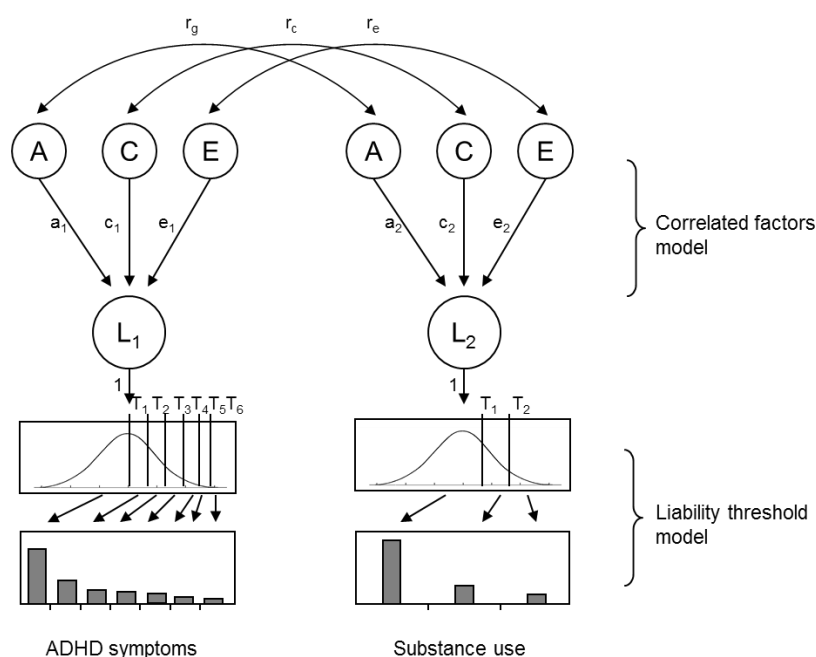

Figure 5. Path diagram depicting the correlated factors model and liability threshold model.

#### 4.5 STUDY IV

In Study IV, we identified all individuals born between 1960 and 1988 with at least one diagnosis of ADHD in the NPR since 2001 (N= 17,408). These patients were followed from 1/1/2006 to 12/31/2009 (48 months) for any serious transport accident. A non-ADHD general population sample, matched 1 to 10 for age, sex, and residential area at the time of the diagnosis was extracted from the TPR.

The PDR was used to obtain information on all prescribed medications since July 2005. In accordance with previous studies [122,127,203], an individual was defined as “under medication” during the interval between two dispensed prescriptions (picked up by the individuals themselves, family members, or health care staff) of ADHD medication, unless the prescriptions occurred more than six months apart. An individual was defined as “off medication” during intervals of six months or more without a



prescription. The main outcome measure was serious transport accident, which was identified as admission to an emergency hospital care or death due to transport related trauma (ICD-10 code: V01-V99) [160] through the NPR and CoD.

To explore the association between ADHD and serious transport accidents, we first compared the rate of accidents between individuals with and without ADHD using Cox regression. Second, we included measured covariates in the model to control for confounding. To investigate the association between ADHD medication and accidents among ADHD patients, we initially used ordinary between-individual Cox regression, with robust standard errors accounting for the correlations between time periods within the same individual. Next, within-individual analyses were performed using stratified Cox regression (see section 4.1.2.2).

To assess the public health impact of ADHD medication on serious transport accidents we used the population attributable fraction (PAF). In the absence of unmeasured confounding, the PAF measures the proportion of accidents that would be eliminated if the whole cohort of ADHD patients was medicated during the follow-up.

Because of the gender difference in ADHD [204] and transport accidents [205], all the analyses were conducted separately for males and females. Since young males are the single most risky demographic group [206], separate analyses were also conducted for young and middle-aged adults.

## **4.6 STUDY V**

In Study V, we identified all individuals between 1960 and 1998 with at least one diagnosis of ADHD in the NPR since 2001. We also used the PDR to obtain information on prescribed ADHD medications. A non-ADHD general population sample, matched 1 to 10 for age, sex, and residential area at the time of the diagnosis was also used.

Substance abuse was defined as [207]: (1) hospital visits with diagnoses of mental and behavioral disorders due to psychoactive substance use (ICD-10 codes: F11-F16, F19) identified from the NPR; (2) deaths due to substance use (ICD-10 codes: F11-F16, F19) according the CoD; (3) convictions for a substance related crime according to the Crime Register (i.e., making, transfer, possession, or use of illegal substances). Substance abuse was treated as a time-to-event variable that could occur repeatedly during follow-up. We included only unplanned hospital visits to avoid misclassifying planned treatments (e.g., regular hospital visits in treatment programs) as events.

We used Cox-regressions with robust standard errors (to account for the correlations between periods within the same individual) to estimate the risk of substance abuse during 2009, with stimulant medication status at January 1 2006 as the exposure. First we investigated the associations while controlling for sex, and age and medication during follow up as time-dependent covariates (Model 1). Second, we controlled for the

other covariates at baseline (Model 2). To investigate whether the duration of treatment was important, we did separate analyses with the total number of years with ADHD medication for 2006-2008 as the exposure.

Finally, to test the effect on short-term abuse we studied the concomitant risk of substance abuse. Similar to Study IV, this was done by within-individual analyses, using stratified Cox regression.

## 5 RESULTS

### 5.1 STUDY I

A model that included additive genetic (A) and non-shared environmental (E) factors and no sex effect provided the best fit with a balance between explanatory power and parsimony. Standardized parameter estimates for the genetic and environmental contribution (as illustrated in the upper part of Figure 4), along with 95% CIs, are shown in Table 3. The relative contributions of genetic and non-shared environmental factors are illustrated in Figure 6.

Table 3. Parameter estimates with 95% CIs for the best-fitting model.

| Factor<br>(Age, y)         | Total<br>$h^2$ (%) | Genetic factors     |                     |                     |                     | Total<br>$e^2$ (%) | Unique environmental factor |                      |                       |                      |
|----------------------------|--------------------|---------------------|---------------------|---------------------|---------------------|--------------------|-----------------------------|----------------------|-----------------------|----------------------|
|                            |                    | A1                  | A2                  | A3                  | A4                  |                    | E1                          | E2                   | E3                    | E4                   |
| AP <sub>1</sub><br>(8-9)   | 77                 | 0.88<br>(0.76-0.99) |                     |                     |                     | 23                 | 0.48<br>(0.04-0.65)         |                      |                       |                      |
| AP <sub>2</sub><br>(13-14) | 82                 | 0.64<br>(0.56-0.73) | 0.64<br>(0.53-0.71) |                     |                     | 18                 | 0.17<br>(-0.06-0.48)        | 0.39<br>(-0.49-0.49) |                       |                      |
| AP <sub>3</sub><br>(16-17) | 82                 | 0.59<br>(0.50-0.67) | 0.47<br>(0.36-0.57) | 0.51<br>(0.42-0.57) |                     | 18                 | 0.09<br>(-0.09-0.48)        | 0.39<br>(-0.48-0.48) | 0.12<br>(-0.28-0.28)  |                      |
| AP <sub>4</sub><br>(19-20) | 78                 | 0.49<br>(0.38-0.60) | 0.39<br>(0.24-0.53) | 0.29<br>(0.14-0.46) | 0.55<br>(0.37-0.66) | 22                 | -0.12<br>(-0.49-0.39)       | 0.25<br>(0.03-0.58)  | -0.37<br>(-0.55-0.55) | 0.01<br>(-0.53-0.53) |

$h^2$ , the proportion of variance in AP explained by genetic factors

$e^2$ , the proportion of variance in AP explained by unique environmental factors

The results revealed that genetic factors had a strong influence on AP, as measured by the shared view of parent and self-ratings, across the four time points (AP<sub>1</sub>-AP<sub>4</sub>). The heritability ( $h^2$ ) estimates for AP<sub>1</sub> to AP<sub>4</sub> were 77%, 82%, 82%, and 78%, respectively. Unique environmental factors ( $e^2$ ) accounted for the remaining part of the variance (i.e., 18%-23%). The first genetic factor (A1) explained 77% ( $0.88^2$ ) of the total variance of AP<sub>1</sub> at age 8-9, and continued to influence AP, although its influence declined over time: it accounted for 41% ( $0.64^2$ ) of the variance at age 13-14, 34% ( $0.59^2$ ) at age 16-17, and 24% ( $0.49^2$ ) at age 19-20. In addition to the temporally stable genetic factor from childhood (age 8-9), new sources of genetic influence on AP emerged at subsequent ages: the second genetic factor (A2) explained 41% ( $0.64^2$ ) of the variance in AP<sub>2</sub> at age 13-14; A3 explained 25% ( $0.51^2$ ) of the variance in AP<sub>3</sub> at age 16-17; and A4 explained 30% ( $0.55^2$ ) of the variance in AP<sub>4</sub> at age 19-20. These new genetic factors (i.e., A2 and A3) also continued to impact later times. In contrast to the genetic factors, the first unique environmental factor (E1) at age 8-9 attenuated sharply over time, while the impact of E2 continued over time, suggesting that some environmental factors around puberty have an enduring impact.

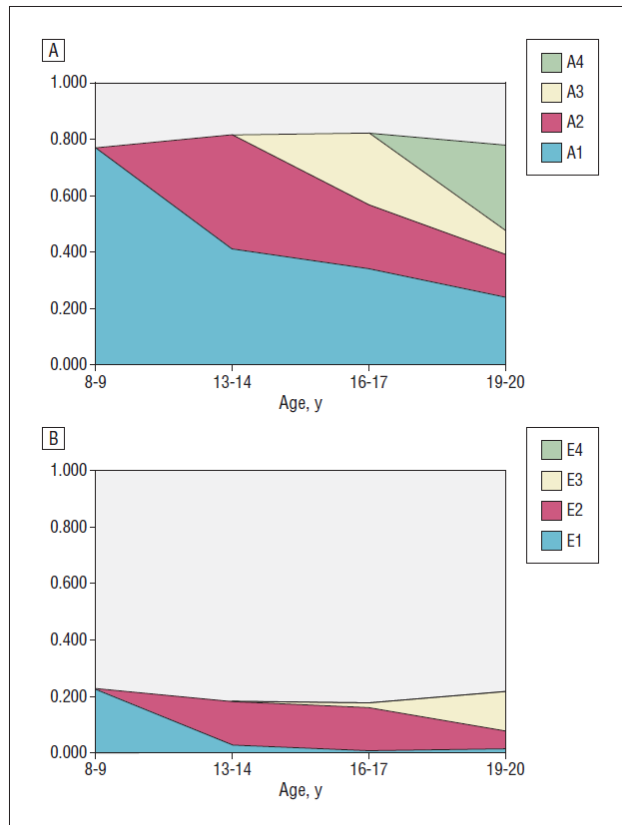

Figure 6. The proportion of the total variance in latent estimation of attention problems explained by genetic factors (A) and unique environmental factors (B) through development.

## 5.2 STUDY II

We first examined the association between MACB and offspring ADHD. Hazard ratios (HRs) with corresponding 95% CIs for MACB are shown in Table 4. Using the binary measure, Model 1 found that teenage childbearing was associated with a 57% increased risk of offspring ADHD (HR = 1.57). However, the negative association disappeared in Model 2 when controlling for MAFB (HR = 0.90) and in model 3 when controlling for unmeasured genetic and environmental factors shared by siblings (HR = 0.80). The same pattern of results was observed when using the continuous measure of MACB. Taken together, the results indicated that offspring born when their mothers were young had no increased risk of ADHD, compared with their later-born siblings. Maternal age at childbearing had no offspring-specific effects.

Table 4. Association between MACB and offspring ADHD (HRs with 95% CIs).

| MACB       | Model 1          | Model 2          | Model 3          |
|------------|------------------|------------------|------------------|
| binary     | 1.57 (1.48-1.67) | 0.90 (0.84-0.96) | 0.80 (0.70-0.92) |
| continuous | 0.95 (0.95-0.96) | 1.01 (1.00-1.01) | 1.02 (1.01-1.03) |

Model 1: Population-wide estimate, adjusted for offspring's gender, birth order in categories, birth year in categories and paternal age at childbirth in categories.

Model 2: Population-wide estimate, adjusted as Model 1 + mother's age at first childbirth.

Model 3: Sibling comparison.

The association between MAFB and offspring ADHD is shown in Table 2. Using the binary measure, Model 4 found that teenage childbearing was associated with a 78% increased risk of offspring ADHD (HR = 1.78). When using cousin comparison in Model 5, the effect of teenage childbearing was somewhat attenuated (HR = 1.33), but it remained a significant predictor for offspring ADHD. We obtained the same pattern of results using the continuous measure of MAFB. The results indicated that MAFB was strongly associated with offspring ADHD, and that part of the association was confounded by familial factors.

Table 5. Association between MAFB and offspring ADHD (HRs with 95% CIs).

| MACB       | Model 4          | Model 5          |
|------------|------------------|------------------|
| binary     | 1.78 (1.72-1.84) | 1.33 (1.18-1.50) |
| continuous | 0.94 (0.93-0.94) | 0.97 (0.96-0.99) |

Model 4: Population-wide estimate, adjusted for offspring's gender, birth order in categories, birth year in categories and paternal age at childbirth in categories.

Model 5: Cousin comparison.

Results of the CoS model showed a moderate heritability of MAFB (47%) and a high heritability of ADHD (71%). Extended-family environment had little influence on either MAFB or ADHD. A significant genetic correlation was observed between MAFB and ADHD (-0.41). Thus, the phenotypic correlation between MAFB and offspring ADHD was mainly explained by a correlation between the genetic liability to MAFB and the genetic liability to ADHD. This result confirmed and extended findings from the cousin comparison, suggesting that the association between MAFB and offspring ADHD was not causal and was, instead, mediated largely through genetic factors that influence the liability to both MAFB and ADHD.

### 5.3 STUDY III

Sample characteristics of ADHD symptoms, CPB and substance use are presented in Table 6. Boys had significantly higher levels of HI, IN and CPB than girls. There were no significant sex differences in the rate of substance use.

The Table 7 presents the results of regression models using symptoms of HI, IN and CPB at age 8–9 to predict substance use at age 13–14. HI significantly predicted both “sometimes” and “often” tobacco use. The association of HI with “sometimes” tobacco use remained significant when IN and CPB were controlled in the adjusted model; one symptom increase of HI at age 8–9 significantly increased the odds of “sometimes” tobacco use at age 13–14 by 12%. The significant association between HI and “sometimes” alcohol use disappeared in the adjusted model. In the unadjusted models, IN predicted “often” tobacco use, “sometimes” and “often” alcohol use, but all significant associations disappeared when adjusting for HI and CPB. This indicated that the contribution of IN to substance use overlapped with HI and CPB. CPB significantly predicted all types of substance use, even after controlling for HI and IN (except for drug use).

Table 6. Sample Characteristics of ADHD symptom, CPB and Substance Use.

|                          | Boys        | Girls       | <i>p</i> |
|--------------------------|-------------|-------------|----------|
| HI <sup>a</sup>          | 1.16 (1.71) | 0.93 (1.47) | <0.01    |
| IN <sup>a</sup>          | 0.86 (1.21) | 0.54 (0.93) | <0.01    |
| CPB <sup>a</sup>         | 1.31 (2.02) | 0.82 (1.64) | <0.01    |
| Tobacco use <sup>b</sup> |             |             | <0.22    |
| “Sometimes”              | 233 (21.8)  | 268 (23.7)  |          |
| “Often”                  | 15 (1.4)    | 24 (2.1)    |          |
| Alcohol use <sup>b</sup> |             |             | <0.66    |
| “Sometimes”              | 176 (16.5)  | 178 (15.8)  |          |
| “Often”                  | 13 (1.2)    | 10 (0.9)    |          |
| Drug use <sup>b</sup>    |             |             |          |
| “User”                   | 35 (3.3)    | 25 (2.2)    | <0.12    |

<sup>a</sup> Mean (SD), age 8-9, *t*-test for sex difference.

<sup>b</sup> Frequency (%), age 13-14, *chi*-square test for sex difference.

Table 7. Risk of substance use at age 13-14 (ORs, with 95% CIs) by ADHD symptoms and CPB.

|                | Substance use at age 13-14 |                  |                  |                  | Illicit drug     |
|----------------|----------------------------|------------------|------------------|------------------|------------------|
|                | Tobacco                    |                  | Alcohol          |                  |                  |
|                | “Sometimes”                | “Often”          | “Sometimes”      | “Often”          |                  |
| HI             |                            |                  |                  |                  |                  |
| Unadjusted     | 1.10 (1.03-1.18)           | 1.32 (1.13-1.56) | 1.11 (1.03-1.20) | 1.17 (0.94-1.46) | 1.16 (0.98-1.37) |
| Fully adjusted | 1.12 (1.03-1.22)           | 1.13 (0.91-1.41) | 1.05 (0.96-1.15) | 0.91 (0.66-1.27) | 1.10 (0.90-1.35) |
| IN             |                            |                  |                  |                  |                  |
| Unadjusted     | 1.00 (0.90-1.10)           | 1.38 (1.12-1.70) | 1.15 (1.04-1.27) | 1.36 (1.04-1.79) | 1.20 (0.94-1.53) |
| Fully adjusted | 0.88 (0.77-1.00)           | 1.04 (0.75-1.46) | 1.01 (0.88-1.15) | 1.14 (0.70-1.89) | 0.94 (0.68-1.30) |
| CPB            |                            |                  |                  |                  |                  |
| Unadjusted     | 1.09 (1.02-1.16)           | 1.31 (1.18-1.46) | 1.15 (1.09-1.23) | 1.29 (1.14-1.47) | 1.16 (1.02-1.33) |
| Fully adjusted | 1.08 (1.00-1.16)           | 1.24 (1.09-1.41) | 1.12 (1.04-1.21) | 1.28 (1.09-1.52) | 1.14 (0.96-1.34) |

Note: The “never use” category of the substance use variables was used as a reference group in all the models. Unadjusted ORs were adjusted only for sex. Fully adjusted ORs were adjusted for sex, the other ADHD dimension, and CPB at the same age.

Since our analyses showed that ADHD’s association with tobacco and alcohol use were specifically linked to the HI dimension, we conducted twin analyses to explore the extent to which these associations were influenced by genetic or environmental factors. To maximize the power, twin analyses were conducted using cross-sectional measures of both HI and substance use at age 13–14. The phenotypic polychoric correlation between HI and tobacco use and between HI and alcohol use were 0.25 (95% CI, 0.15–0.34) and 0.22 (95% CI, 0.11–0.32), respectively. The parameter estimates from the best-fitting model, which constrains the genetic, shared and non-shared environmental parameters to be the same for boys and girls, is presented in Table 8. HI showed a high heritability ( $h^2=0.81$ ), and tobacco use showed a moderate heritability ( $h^2=0.60$ ). A significant genetic correlation was observed ( $r_g=0.30$ ), and 82% of the phenotypic

correlation between HI and tobacco use was explained by genetic influence. Similar pattern of results were observed for HI and alcohol use.

Table 8. Parameter estimates of genetic and environmental effects (95% CI) from bivariate correlated factor models.

|                           | $h^2$               | $c^2$               | $e^2$               | $r_g$               | $r_c$                 | $r_e$                 | G%* |
|---------------------------|---------------------|---------------------|---------------------|---------------------|-----------------------|-----------------------|-----|
| <b>HI and tobacco use</b> |                     |                     |                     |                     |                       |                       |     |
| HI                        | 0.81<br>(0.68-0.86) | 0.00<br>(0.00-0.10) | 0.19<br>(0.14-0.26) | 0.30<br>(0.11-0.57) | 0.01<br>(-1.00-1.00)  | 0.31<br>(-0.09-0.53)  | 82% |
| Tobacco use               | 0.60<br>(0.40-0.83) | 0.28<br>(0.07-0.47) | 0.11<br>(0.07-0.17) |                     |                       |                       |     |
| <b>HI and alcohol use</b> |                     |                     |                     |                     |                       |                       |     |
| HI                        | 0.81<br>(0.68-0.86) | 0.00<br>(0.00-0.10) | 0.19<br>(0.14-0.26) | 0.39<br>(0.19-0.76) | -0.00<br>(-1.00-1.00) | -0.16<br>(-0.50-0.19) | N/A |
| Alcohol use               | 0.61<br>(0.33-0.88) | 0.22<br>(0.00-0.46) | 0.17<br>(0.11-0.26) |                     |                       |                       |     |

\* G%, proportion of phenotypic correlation explained by shared genetic influence.

## 5.4 STUDY IV

Males with ADHD showed significantly higher rates of accidents than males without ADHD (Table 9); the unadjusted HR was 2.45. This association was attenuated but remained significant, after controlling for socio-demographic factors, previous psychiatric diagnosis, other psychotropic medications, and criminal convictions (HR = 1.47). The results for females were similar (adjusted HR = 1.45).

Table 9. Association between ADHD and serious transport accidents in Swedish adults.

| Gender  | ADHD     | Person-years<br>at risk | Number of<br>accidents | Crude association |           | Adjusted association |           |
|---------|----------|-------------------------|------------------------|-------------------|-----------|----------------------|-----------|
|         |          |                         |                        | HR                | 95% CI    | HR                   | 95% CI    |
| Males   | ADHD     | 41,793                  | 897                    | 2.45              | 2.27-2.65 | 1.47                 | 1.32-1.63 |
|         | non-ADHD | 415,662                 | 3,217                  | 1                 | -         | 1                    | -         |
| Females | ADHD     | 27,399                  | 330                    | 2.10              | 1.86-2.38 | 1.45                 | 1.24-1.71 |
|         | non-ADHD | 271,866                 | 1,417                  | 1                 | -         | 1                    | -         |

To explore the association between ADHD medication and serious transport accidents, all subsequent analyses were based on ADHD patients. Comparing the accident rate during medication and non-medication periods in males showed that ADHD medication decreased the accident rate by 29% (HR= 0.71), as shown in Table 10. The association was not statistically significant in females (HR=0.92). Since patients receiving medication might be different from the non-medicated patients, a within-individual analysis comparing the risk between medication and non-medication period is a more informative test of the association. For men, the stratified Cox Regression

showed that medication decreased the accident rate by 58% in males (HR=0.42, Table 8). This illustrated that even within an individual ADHD medication was associated with a significant reduction of accidents, after controlling for all confounds that are constant during follow-up and measured time-varying covariates. Again, we did not observe a significant association among females.

Table 10. Rate of serious transport accident during medication periods compared to non-medication periods among Swedish adults with ADHD.

| Gender  | Medication    | Person-years at risk | Number of accidents | Between-individual |           | Within-individual |           |
|---------|---------------|----------------------|---------------------|--------------------|-----------|-------------------|-----------|
|         |               |                      |                     | HR                 | 95% CI    | HR                | 95% CI    |
| Males   | medicated     | 8,377                | 144                 | 0.71               | 0.57-0.89 | 0.42              | 0.23-0.75 |
|         | non-medicated | 33,416               | 753                 | 1                  | -         | 1                 | -         |
| Females | medicated     | 6,195                | 67                  | 0.92               | 0.78-1.23 | 2.35              | 0.83-6.64 |
|         | non-medicated | 21,204               | 263                 | 1                  | -         | 1                 | -         |

Our estimates of the PAF suggest that, under certain assumptions, 41% to 49% of the accidents in male patients with ADHD could have been avoided if they had been medicated during the entire follow-up.

## 5.5 STUDY V

We investigated long-term associations between stimulant ADHD medication and substance abuse by comparing patients on medication with those not on medication on January 1, 2006. Patients on medication did not have increased rates of substance abuse during follow-up; on the contrary, the rate of abuse during 2009 was lower for those on medication on January 1, 2006 (Table 11). After controlling for age, sex and medication in 2009, the substance abuse rate decreased by 48% (HR = 0.52, Model 1). The decrease in rate was 31% when we controlled for other potential confounders in Model 2 (HR=0.69). For each year an individual took stimulant ADHD medication before the follow-up there was a 13% (HR=0.87, 95% CI: 0.80-0.94) decrease in the rate of substance abuse registrations during 2009, after controlling for all confounders before 2006. Therefore, the results suggested no indication of increased risks of substance abuse among individuals prescribed stimulant ADHD medication.

In addition to long-term effects, we also investigated short-term associations between stimulant ADHD medication and concomitant substance abuse in the cohort of 26,393 men and 12,548 women with an ADHD diagnosis, who were alive in 2006. Concomitant substance abuse was less common during periods with stimulant ADHD medication according to the between-individual analyses (HR=0.57). Similar to Study IV, a within-individual analysis was performed by comparing the risk between medication and non-medication periods. The within-individual estimate of HR was



0.73 (95% CI: 0.68-0.77). Thus, even within individuals, stimulant ADHD medication reduced the concomitant substance abuse rate by about 27%.

Table 11: Stimulant ADHD medication in 2006 and hazard ratio for substance abuse during 2009.

|  | Model 1 |           | Model 2 |           |
|--|---------|-----------|---------|-----------|
|  | HR      | 95% CI    | HR      | 95% CI    |
| Stimulant ADHD medication<br>in January 1, 2006                                  | 0.52    | 0.42-0.66 | 0.69    | 0.57-0.84 |
| Duration of treatment with<br>stimulant ADHD medication<br>2006- 2008 (in years) | 0.80    | 0.73-0.88 | 0.87    | 0.80-0.94 |

Model 1: Adjusted for sex, age and ADHD medication in 2009 as time-dependent covariates.

Model 2: In addition to model 1, adjusted for socio-demographic factors (civil status, employment, study, living in metropolitan area, income), non-substance abuse psychiatric diagnoses, non-substance-related criminal convictions, and substance abuse at baseline.

## **6 DISCUSSION**

### **6.1 FINDINGS AND IMPLICATIONS**

The findings of this thesis indicate that ADHD is highly heritable from childhood to early adulthood. Young maternal age at childbearing is associated with increased risk for subsequent ADHD in offspring, but the association is probably best explained by genetic confounding. ADHD predicts transport accidents and substance abuse, and ADHD medications appear to be useful in reducing the rate of these adverse consequences of ADHD.

#### **6.1.1 Heritability of ADHD throughout development**

Study I found that the shared view of self- and informant-rated ADHD, measured using the AP scale, was highly heritable in childhood, adolescence, and early adulthood.

To our knowledge, this study is the first to show that multi-informant ratings of ADHD-related phenotypes in adults are highly heritable, which is consistent with findings from clinical-based family studies that show a high familial loading on ADHD in adults [133]. One possible explanation is the use of multiple informants. In the basic twin model, the non-shared environmental (E) component captures the variance due to both unique environmental influences and measurement error. The multi-informant design, used in this study, enabled us to distinguish true unique environmental effects from variance explained by rater-specific measurement error. Our results suggest that heritability estimates for ADHD are stable during the transition from childhood into young adulthood and that the previous reports of low heritability for ADHD symptoms in adults are best explained by rater effects attributable to measurement error, rather than by developmental effects.

The developmental design of this study allowed us not only to make the cross-sectional heritability estimates across different ages, but also to distinguish between stable and dynamic genetic factors during development. We found evidence of both stable and dynamic genetic influences over the course of the development from childhood into early adulthood. Consistent with the available literature [208-211], our results suggest that molecular genetic studies of ADHD symptoms in adults will identify genes that are shared with childhood ADHD, which represent developmentally stable genetic influences. Such studies will also identify genes that become active later in life that may involve processes that lead to the persistence or remission of the disorder as children with ADHD grow older. Taken together, our findings indicated that a multi-informant measure of ADHD can identify a highly heritable phenotype and that different genetic risk factors account for the heritability at different stages of development. Therefore, the use of longitudinal samples with multi-informant measure may be able to refine phenotype with less heterogeneity, to be able to identify replicable genetic variants associated with ADHD.

A critical assumption for longitudinal studies is that the phenotype under study “looks” the same across development. The finding of dynamic genetic influences may partly reflect differences across time in the assessment of AP. In contrast to this alternative explanation, we observed similar heritability estimates with sensitivity analyses using (a) DSM-oriented ADHD scale from the empirically based assessment (CBCL, YSR, ABCL and ASR) [183,212], and (b) a reduced number of AP items that were same at all times and for all scales.

### **6.1.2 Young maternal age and offspring ADHD**

Study II examined the association between maternal age at childbearing and offspring ADHD, and the results supported two main conclusions. First, maternal age at first birth (and not maternal age at the current birth) predicted offspring ADHD. Thus, all offspring born to a mother who began childbearing early were at increased risk of ADHD. It is particularly important for prevention purposes to be aware of that later-born offspring of teenage mothers are also at increased risk of developing ADHD.

Second, the association between MAFB and offspring ADHD was mainly explained by genetic confounding attributable to passive gene-environment correlations. That is, genetic factors transmitted from mothers to children contributed to both age at childbearing and ADHD in offspring. A similar result was found in a study on maternal age and cognitive test score [213]. In contrast, other studies have provided support for a causal mechanism underlying the association between MAFB and offspring disruptive behaviors and criminal convictions [139,140]. The conflicting results might suggest different etiologies for ADHD and other externalizing psychopathology. If MAFB is causally associated with offspring outcome, then it represents shared environmental influence within a nuclear family. Our results found little shared environmental influence on ADHD, which is consistent with a meta-analysis of twin studies [214] that reported that shared environmental influence accounted for 10%-19% of the variance within broad externalizing disorders, and the only exception was ADHD, which appeared to be largely genetic in origin.

Teenage childbearing is internationally recognized as a public health issue with adverse consequences for both young mothers and their children [138]. Although young maternal age itself does not cause offspring ADHD, it is an important risk marker for all children born to young mothers. Our results suggest that public policy initiatives should strive not only to delay childbearing in the population, but to identify individual at-risk mothers and their children who may need support. Our findings are also likely to contribute to the understanding of the etiology of ADHD. What are usually believed to be environmental risk factors may also be markers of genetic predispositions. Our results highlights the importance of using genetically informative studies when trying to understand how early life circumstances affect child development.

### **6.1.3 ADHD and early-onset substance use**

Study III found that the hyperactivity-impulsivity symptom dimension of ADHD, but not inattention, independently predicted early-onset tobacco use, even after controlling for CPB. In line with previous research [95], our prospective findings suggest that hyperactivity-impulsivity and CPB make unique contributions to the risk of smoking initiation (“sometimes” use). These results are consistent with the hypothesis that the association between childhood behavior and substance use is not entirely attributable to the developmental tracking of antisocial behavior, but is part of a more general process of behavioral disinhibition [215]. In contrast to our findings, several previous studies have found an independent association between inattention and later substance use [96,149,150], which supported the self-medication hypothesis. However, these studies focused on substance use during mid-adolescence and early-adulthood, whereas we studied early-onset substance use. This difference is important since prior research suggests differences in etiology between substance use in mid-adolescence/early adulthood and the less common early-onset type [216,217]. In addition, developmental research suggests different substance use trajectories, including an early-onset group and a late-onset group, which vary in severity and persistence [218-220].

The twin analyses showed that the association between hyperactivity-impulsivity and early-onset substance use were mainly influenced by genetic factors. Our results are consistent with accumulating evidence of a common behavioral and neurobiological bases for ADHD and smoking [221]. Unfortunately, because of the limited sample size and the use of categorical measures, we did not have sufficient power to simultaneously include hyperactivity-impulsivity and CPB in a multivariate design that could clarify whether the shared genetic liability with substance use is specific to hyperactivity-impulsivity, or common to other behavior problems.

### **6.1.4 ADHD, transport accidents, and the effect of medication**

Study IV found that ADHD patients had increased risk for serious transport accidents and that ADHD medication was associated with reduced rates of accidents in males patients, even when using within-individual analyses.

The study found that men and women with ADHD had 42% - 47% increased rate of serious transport accidents compared to individuals without ADHD. The magnitude of the association was similar to results from a population-based, case-control study in North American [160]. Studies have suggested that visual inattentiveness and impulsiveness are the largest contributions to the risk of transport accidents in ADHD patients [108]. Medications that alleviate ADHD symptoms might be expected to translate into safer driving behavior and, therefore, to reduce the risk of accidents [222]. Consistent with experimental and clinical studies on the effect of medication on driving [107,159,161,223], our results clearly indicate that ADHD medication was associated with reduced rates of serious transport accidents.

This is the first population-based study of ADHD medication and serious transport accidents. Population-based register data have several strengths compared to clinical studies. The sample size is substantial and representative for the population, therefore avoiding referral bias, selective participation, and other threats to validity and generalizability. Nevertheless, observational studies are always susceptible to selection effects [125]. A major threat in studies of medications is that some patients might receive medication because they are different (usually more symptoms or with comorbid conditions). Unlike RCTs, which randomly assign participants to treatment conditions, observational studies like ours cannot control for all possible confounders that select individuals to treatment. Our main attempt to control for this was to use within-individual analyses, which adjusts for all potential confounders that are constant during the follow-up (genetic predisposition and early environment). However, unmeasured confounders and mediators that vary during follow-up (engagement with services that provide prescriptions, cyclic nature of the disorder itself, substance use, or crime) cannot be completely ruled out by this research design. Although all of the sensitivity analyses were consistent with a causal hypothesis, they were only suggestive. Thus, future RCTs or observational studies that include information about medication dosage are obviously needed.

Our estimates of the PAF suggested that, under certain assumptions, 41% to 49% of the accidents in male patients with ADHD could have been avoided if they had been medicated during the entire follow-up period. It is important to note, however, that the PAF estimates will be lower in countries with higher prescription rates than Sweden [128,129] and that the beneficial effects of ADHD medication needs to be weighed against potential adverse effect, including side effects and over-prescription.

Transport accidents are a major public health problem. Our findings call attention to a prevalent, preventable and costly cause of mortality and morbidity. The association between ADHD and serious transport accidents does not, by itself, justify withholding a driver's license; nevertheless our findings indicate that a large number of injuries and death from traffic accidents associated with ADHD occurred during periods when patients were off medication. Clinicians should consider telling patients about the increased risk for transport accidents associated with ADHD, as well as, the possible benefits of ADHD medication. This would provide opportunities not only to reduce morbidity and mortality among ADHD patients, but also to contribute to public safety in transport.

### **6.1.5 ADHD medication and risk of substance abuse**

ADHD medication has been shown to have advantageous short-term effects on ADHD symptoms, as well as reducing concomitant criminality [122] and transport accidents (Study IV). Even though the short-term effects can be beneficial, there has been a persistent concern that treatment with stimulant medication could lead to long-term development of substance abuse. In Study V we followed almost 40,000 individuals with ADHD over 4 years, and found no indication of increased substance abuse, which

is consistent with a recent meta-analysis [163]. Rather, the results indicated there was a decrease in substance abuse for up to four years after taking medications, and that patients who took ADHD medications for longer durations had lower rates of substance abuse. Critics of ADHD medication have been specifically concerned about the substance abuse risk for youth [172,224,225], but we found no indication of long-term increase in substance abuse in this group.

One possible mechanism of the long-term association between ADHD medication and substance abuse would be that ADHD medication leads to less exposure to substances and, thus, less chance of developing dependence or addiction. An alternative explanation to the results is reverse causation. That is, that substance behavior before 2006 is correlated with substance abuse in 2009 and that the earlier substance abuse (which may have been subclinical) decreased the likelihood of being prescribed ADHD medication. However, several sensitivity analyses indicated that the results were not likely to be explained by reverse causation.

Again, it should be noted that observational studies are susceptible to selection effects. In our analyses of short-term associations, we addressed this problem using within-individual analyses and found similar reduction in substance abuse rates, but it was not possible to do this for long-term associations. Ideally, these results should be replicated in RCTs, but a trial of long-term effects of ADHD medication is unlikely to be feasible because of practical and ethical reasons.

In summary, although we argue that concerns over long-term risks for substance abuse following ADHD medication probably have been overstated, the decision to prescribe stimulant ADHD treatment should, as in all clinical practice, take into account individuals factors and potential adverse effects. Future studies are needed to evaluate the long-term effect of ADHD medication on other important medical risks, for example, cardiovascular risk [226] and suicide [227]. When considering ADHD medication, it is also important to acknowledge the risk for over-prescription; clinicians should remain alert to the problem of stimulant misuse and diversion [228].

## **6.2 METHODOLOGICAL CONSIDERATIONS**

### **6.2.1 Measurement issues**

#### *6.2.1.1 Assessment of ADHD*

The main phenotype in this thesis is ADHD, and it has been used as exposure, outcome, and definition of cohort in different studies.

In Study I and III, we used questionnaire-based ADHD symptoms. In Study I, we used the parent- and self-ratings of AP scale to measure ADHD symptoms. In Study III, we used parent-ratings of DSM-based ADHD symptoms. Both measures have been used in many previous epidemiological studies of ADHD, representing good psychometric properties, as described in the study sample section (3.1.3). However, they have some limitations that need to be mentioned. First, the AP scale was not specifically designed

to identify the two symptom domains of ADHD (inattention and hyperactivity-impulsivity), and this may have limited its ability to detect subtype-specific dominant genetic effects. Also, some of the items in the AP scale are not ADHD specific (e.g., acts young, daydreams). Second, although the parents were asked to rate their children's behavioral problems exhibited in the past six months, it is possible that ratings in early adulthood (age 19-20 years) may be influenced by the offspring's behavior at earlier ages. Third, the measure of ADHD in Study III has not been formally validated, and because of the definitional changes in the DSM during the follow-up period, our measurements did not cover all of the HI and IN symptoms included in the DSM-IV. However, the instrument has been previously used in several epidemiological studies that replicated several well-established findings in the ADHD literature [32,134,175,176]. In addition, the measure of ADHD in Study III relied on only parent reports, which might inflate the twin correlations. However, the heritability estimate from Study III was similar to that from Study I, which used multi-informants. Finally, because symptoms of ADHD were measured using questionnaires in a population-based twin sample, it is not certain that the results are generalizable to clinical settings.

In Study II, we used register-based ADHD diagnosis as the outcome. To improve sensitivity, we used a conjunctive definition of clinical ADHD, including individuals either received ADHD diagnoses according to the NPR *or* treated with ADHD medication according to the PDR. In general, Swedish psychiatrists are rather conservative with respect to diagnosis and medication, and they tend to complete detailed clinical assessment. Thus, the register-based ADHD diagnosis should represent high specificity. This is also supported by our own validity check on the register-based ADHD diagnoses using a young cohort of twins with psychiatric symptom data [229]. Nevertheless, future studies should formally validate the diagnosis of ADHD using Swedish registers.

In Study IV and V, we used register-based ADHD diagnoses to define the patient cohort, which included patients with at least one diagnosis of ADHD in the NPR since 2001. Historically, some counties have been less consistent in reporting outpatient data to the NPR. To address this potential selection bias, we also analyzed cohorts of individuals that received at least one prescription for ADHD medication during follow-up (identified from the PDR, which has complete coverage), but not necessarily had a registered ADHD diagnosis, and both analyses yielded comparable results.

With respect to its associations with genetic and environmental risk factors, ADHD appears to behave like a dimensional measure rather than as a qualitative discrete category [13]. Although a clinical diagnosis of ADHD is essential to identify individuals who need care and treatment, research, ideally, should use both clinical diagnosis (case/no-case) and measures of symptom dimensions. Dimensional approaches are valuable to use because they are more sensitive for studying risk factors and adverse consequences related to ADHD, whereas clinical diagnosis is valuable to use in order to be able to generalize the results to clinical populations.

### 6.2.1.2 *Measurement of ADHD medication*

In Study IV and V, we measured ADHD medication using dispensed prescriptions, and our study might be affected by poor compliance with medication adherence. This is similar to the situation in RCTs and our effect estimate can be compared to an intention to treat analysis. We used a 6-months cutoff between prescriptions to define “off medication” based on previous research. To explore the potential influence of exposure misclassification, we re-analyzed the data with a 3-months cutoff and found similar result (Study IV). If some individuals did not take medication as prescribed, this would reduce the effect estimates; hence, our findings are probably conservative estimates of the actual effects of medication on transport accidents.

### 6.2.1.3 *Measurement of other outcomes*

There are measurement issues regarding other outcomes that also need to be discussed. Substance use in Study III was measured only by self-reports, which could be considered a limitation of the study [230]. Although most epidemiological research on substance use disorders rely on self-reports, family or peer reports may have strengthened the results. Nevertheless, self-reports may be the preferred method to measure substance use among adolescents in community settings [231], because adolescents may be more likely to reveal private information in an anonymous questionnaire than to their parents.

In Study IV we used emergency hospital visits or deaths from transport accidents as our primary outcome, which are fairly serious outcomes. Similarly, in Study V we used medical and legal records of substance-related hospitalizations, deaths and convictions to measure substance abuse. While using information from registers has the important advantage of precluding recall bias, registers included mainly cases of serious outcomes. Future research needs to explore whether our findings generalize to less severe outcomes.

## 6.2.2 **Causal inference from observational data**

"Correlation is not causation" is a mantra in epidemiology and statistics. Although many factors have been identified that are correlated with ADHD, their causal connection to ADHD is not well established. A correlation between two variables (e.g., exposure and outcome) is often found in observational studies, which may imply that the exposure has a causal effect on the outcome. However, the observed correlation could have alternative explanations. The use of longitudinal designs and representative samples can eliminate some alternative explanations, such as selection bias or reverse causation. The following discussion will focus on controlling bias from confounding that is the most common threat to making causal interpretations from observational studies. Causal effects are defined according to the modern "counterfactual model", and all causal effects refer to ‘average causal effects’ in a population [232].



Experimental designs offer the most plausibly unbiased estimates of causal effect. In RCT's, individuals are randomly assigned to different treatments so that the different treatment groups should not differ significantly from each other on their observed or unobserved characteristics, at baseline, assuming an adequate sample size. Therefore, any observed differences in outcomes can be explained only by the differences in the treatments. However, RCTs are often not feasible because of cost or ethical reasons.

In observational studies, many efforts are taken to control or reduce biases produced by confounding. From a research design perspective, matching participants on potential confounding variables provides a straightforward strategy, in which case-control groups or exposed-unexposed groups are created based on matching variables. From an analytic perspective, stratification and multivariate regression analyses are the most commonly used methods. Each approach has its advantages and disadvantages. However, these approaches have the common limitation that they can control for only those confounders that are measured, and only to the extent that they are measured correctly.

Quasi-experimental designs offer an attractive alternative. Family-based, quasi-experimental designs can provide highly informative tests of causal hypotheses by substantially reducing genetic and environmental confounding (see section 4.1.2). By studying associations within sets of family members (e.g., siblings), the analysis automatically controls for unmeasured genetic and environmental factors shared by siblings, without having to model or even measure these factors (Study II). However, influence of non-shared confounders and measurement errors cannot be ruled out in such designs, interpretation of the results should be made with caution [199].

Time-series within-individual analysis represents another powerful quasi-experimental design. Within-individual estimates automatically adjust for confounding by all unmeasured covariates that are constant within each individual during the follow-up period (e.g. genetic predisposition and early environments) (Study IV and V). It should be noticed that within-individual analysis cannot adjust unmeasured confounders that varied during follow-up (e.g., engagement with health care services, cyclic nature of diseases).

In addition to reducing potential confounding, one can use negative control analyses to estimate the magnitude of influence of confounding. Negative control analysis examines the association between exposure and outcome, using (a) an outcome that is presumed not to be causally associated with the exposure (negative outcome control), or (b) an exposure that is presumed not to be causally associated with the outcome (negative exposure control). If the negative control analysis finds associations similar to the initial analysis, then the initial analysis is likely to be biased by confounds. On the other hand, if one finds an association in the initial analyses, but no association in negative controls, the causal interpretation is strengthened. In Study IV we used selective serotonin reuptake inhibitor as a negative control, when studying the association between ADHD medication and transport accidents. This analysis enabled

us to compare the general effects of being prescribed medication (which might be influenced by time-varying confounding, such as access to medical service) with the specific effects of ADHD medication.

Mendelian randomization is another recent development in causal inference, which relies on the random assignment of each individual's genotype, and can be considered as analogous to RCTs [233]. While none of designs can completely control for all potential confounding, well-designed observational studies can substantially reduce the number of alternative explanations of apparent causal effects. Moreover, confidence in a finding is strengthened when different designs with different flaws support the same conclusion.

### **6.2.3 Twin methodological issues**

The findings of Study I and III should be considered within the context of several basic assumptions underlying twin methodology.

#### *6.2.3.1 Equal environment assumption*

One of the fundamental assumptions in twin methodology is the equal environment, which assumes that environmentally caused similarity is roughly the same for both types of twins (i.e., MZ and DZ) reared in the same family. The assumption is violated if MZ twins are treated more similarly than DZ twins, which in turn would inflate the estimate of genetic effect. Although the equal environment assumption has been debated, various checks, such as incorporating environmental measures in twin studies and analyzing the effects of mistaken zygosity, suggest that the assumption is generally valid [234]. Specifically, studies have found the assumption is valid for ADHD and other psychiatric disorders [235,236].

#### *6.2.3.2 Assortative mating*

The basic twin model assumes random mating in the parent generation. Assortative mating occurs if individuals with similar phenotypes mate with one another more frequently than individuals with dissimilar phenotypes. If the phenotypic similarity is due to genetic similarity, the offspring will be genetically more similar. Assortative mating increases similarity in DZ twins, thereby underestimating the genetic influence and overestimating the shared environmental influence. Consistent with previous research [214], we found no evidence of shared environmental influence on ADHD, suggesting that the potential effect of assortative mating is minimal.

#### *6.2.3.3 Non-additive genetic effect*

The basic twin model often focuses on additive genetic effects, assuming that the effects of alleles at a locus and across loci are independent and, therefore, additive. However, the effect of alleles can also interact with other alleles at the same locus (dominance) or at other loci (epistasis) [234]. Non-additive genetic effects may be present if DZ correlations are less than half of MZ correlations. If non-additive genetic

effects are present but not modeled, this variance will be estimated as additive genetic variance. Study I found evidence that at least part of the heritability of AP is due to non-additive genetic effects.

#### *6.2.3.4 Gene-environment interaction/correlation*

The basic twin model assumes that influences of genes and environments on a phenotype are independent. In addition to the direct effects of genes and environments, there may be an interplay between them through gene-environment interactions and correlations [147]. Gene-environment interactions refer to the possibility that individuals of different genotypes may respond differently to environments. Susceptibility gene variants for ADHD have been identified with emerging evidence of gene-environment interaction [237]. Gene-environment correlations refer to the possibility that individuals with different genotypes are selectively exposed to different environments. The finding in Study II provided an example of gene-environment correlation; that is, a putative environmental risk factor (i.e. young maternal age) was influenced by genetic factors, which were transmitted from parents to their offspring and accounted for the risk of ADHD.

#### *6.2.3.5 Generalizability from twins to singletons*

Twins may differ from singletons with respects to lifestyle characteristics and psychological development [238,239]. Although numerous studies suggest that the results of twin studies can be generalized to singleton populations [240,241], the nature of the sample has to be taken into account when interpreting results from twin studies. In any case, two previous reports have shown that the mean levels of emotional and behavior problems (measured by CBCL) in the current TCHAD sample is similar to that found in other Swedish samples [242,243].

### **6.3 GENERALIZABILITY**

All the studies in this thesis used data from the Swedish population, and the rates of ADHD and ADHD medication use, and other variables studied in this thesis (e.g., teenage childbirth, traffic fatality and disability, use of illegal drugs) are lower in Sweden compared to other developed countries (e.g., the United State) [16,129,138,157,244,245]. However, the magnitude of the heritability of ADHD and the associations of other study variables with ADHD were generally similar to those reported in studies from other countries. Nevertheless, we cannot claim that our findings are the same as those from other cultures/countries and, thus, generalizations from the current studies should be made with caution.

## 7 CONCLUSIONS

- I. ADHD is highly heritable in childhood, adolescence, and early adulthood, suggesting that the previous reports of low heritability for ADHD in adults are best explained by rater effects. Both stable and dynamic genetic influences are present over the course of the development.
- II. Maternal age at first birth (and not maternal age at the current birth) predicted offspring ADHD. Thus, all offspring born to teenage mothers were at increased risk of ADHD. This association is mainly explained by genetic confounding. That is, genetic factors transmitted from mothers to children contribute to both mother's age at childbearing and ADHD in offspring.
- III. Hyperactivity-impulsivity symptoms, but not inattention, independently predict early-onset tobacco use, even after controlling for conduct problems, and this association was mainly explained by shared genetic factors.
- IV. ADHD is associated with an increased risk of serious transport accidents, and this risk seems to be reduced by ADHD medication, at least among male ADHD patients. These findings indicate the need for increased awareness of the association between serious transport accidents and ADHD medication among clinicians and patients.
- V. There is no indication of increased risks of substance abuse among individuals prescribed stimulant ADHD medications, and the results suggest there may be a long-term protective effect of such medications on substance abuse. Although stimulant ADHD medications do not seem to increase the risk for substance abuse, clinicians should remain alert to the potential problem of stimulant misuse and diversion in ADHD patients.

## 8 FUTURE PERSPECTIVES

### 8.1 TWIN STUDIES IN THE OMICS ERA

The classical twin model can provide insight into the etiology of diseases, and it has revealed the importance of genetic influence on many diseases, including ADHD. During the last years, GWAS has provided a revolutionary approach to search for genetic variants susceptible to disease. In the current era of molecular genetics, the use of classic twin studies combined with novel technologies should continue to provide valuable insights to the understanding of complex diseases [246].

There is an ongoing discussion about “missing heritability”, which largely stems from the disparity between the heritability estimates from twin studies and the proportion of variance explained from GWAS [247]. One argument is that the heritability from twin studies may be overestimated. A recent approach has been proposed to estimate heritability directly from DNA similarity (genome-wide identity-by-descent sharing) [248]. The estimate of heritability of height based on genome data was highly consistent with results from classical twin studies, which provided strong support for the heritability estimate from twin studies. The validity of heritability estimates from twin studies is further supported by the finding that common SNPs explain a large proportion of the heritability of height, schizophrenia and bipolar disorder [249,250]. Thus, most of the heritability of complex traits is not missing, although it has not been detected yet.

The few GWASs on ADHD performed so far have failed to identify any common genetic variant that reaches the genome-wide significance level. One explanation could be due to the heterogeneous nature of the disorder, and twin study can provide predictions and refined phenotypes for molecular genetic studies [251]. Longitudinal twin model can identify stable genetic influences through the development of a disease, as well as age-specific genetic influences. Similarly, multivariate twin model can identify shared genetic influences across several comorbid disorders, as well as disorder-specific genetic influences.

Twin studies can also help to identify endophenotypes of behavioral disorder. Endophenotypes are considered as intermediate phenotypes in the pathway between genes and disorder, with a simpler etiology than the complex, often heterogeneous disorder itself [252]. Neuropsychological measures, structural and functional neuroimaging and electrophysiological paradigms have been suggested as potential endophenotypes for ADHD, which show correlations with ADHD and evidence of heritability [253]. Twin studies can be an important tool to identify the genetic overlap between these constructs and ADHD [254].

In addition to providing estimates of genetic and environmental influences, the comparison of discordant twins (especially discordant MZ twins, also known as co-twin control method) is a powerful tool compared to the traditional case-control study.

The discordant twin design has long been used to test the causality of putative environmental risk. It also offers a unique opportunity to study biological processes (e.g., DNA methylation, gene expression) against an equivalent genetic background [247].

Twin registries worldwide have collected longitudinal data on thousands of twins, providing valuable resources for studying complex disorders. Pooling information from available twin registries will further increase the analytical power of studies and provide a unique opportunity for large-scale studies on complex disorders.

## **8.2 BEYOND GENETIC AND ENVIRONMENTAL RISK FACTORS**

Although many environmental factors have been proposed as risk factors for ADHD, for the most part their causal connection to ADHD remains unclear. It is also unclear whether these factors influence the risk of ADHD independently, or interactively. Moreover, if they do interact, it is unknown to what extent they interact with each other, or with genetic factors. Gene-environment interactions are likely to be a common and important source of variation in complex behavioral traits. Genetic predisposition can influence vulnerability to environmental stress, and environmental exposure can also influence the expression of susceptible genes. Many studies have reported candidate gene by environment interaction in the development of ADHD [255,256]. Twin studies can provide evidence of gene-environment interaction by showing how genetic influences on a trait are changed by environmental moderators [257], and can provide targets for future genome-wide searches for gene-environment interactions. Gene-environment interactions are also an important potential explanation for the “missing heritability” [258]. Increasing knowledge of the genetic and environment interplay on ADHD could lead to a better understanding of the biological mechanisms of ADHD.

We know that ADHD is associated with a wide range of adverse outcomes, but little is known about to what extent ADHD predicts these outcomes independently of other factors, and how ADHD and other factors jointly predict these outcomes. For example, ADHD patients with a particular environmental exposure may have a high risk for occupational difficulties, but no increased risk for driving problems. Patients with another environmental exposure may have a high risk for substance abuse. Because ADHD typically starts early in childhood, a predictive model of adverse outcomes is essential for prevention and intervention. Therefore, future research is needed to explore how various factors (including ADHD) predict the risk of different adverse outcomes, and to identify high risk groups for prevention and intervention. By alerting parents of adverse outcomes, and routinely screening for these conditions, these adverse outcomes could be prevented, or treated at an early stage if they emerged. The same reasoning applies to prediction of persistence versus remission of ADHD in adults. In view of the increasing number of ADHD diagnoses, such advancements can have a substantial impact on health economics globally.

## 9 ACKNOWLEDGEMENTS

I would like to express my sincere gratitude to everyone who has helped me during my PhD study. This thesis could not have been completed without all your contribution. Thank you for all the support and encouragement in this exciting journey. I would especially like to thank:

Henrik Larsson, my main supervisor – thank you for sharing your deep knowledge in psychiatric epidemiology, for showing your great enthusiasms in science, and for your guidance, understanding and trust since the first day. It's never too much to thank you, and I could not have wished for a better supervisor!

Paul Lichtenstein, my co-supervisor – thank you for showing me the value of asking good research questions, and how to find out the answers. Also, thank you for introducing me to your fantastic research group.

Arvid Sjölander, thank you for sharing your profound knowledge in biostatistics and causal inference.

Weimin Ye, my mentor, thank you for the inspiring discussions about scientific career.

Brian D'Onofrio, Eva Serlachius, Linda Halldner, Niklas Långström, Philip Asherson, Ralf Kuja-Halkola, and Seena Fazel, my excellent co-authors, thank you for your important contributions and suggestions when preparing the manuscripts in this thesis.

Hans-Olov Adami, Nancy Pedersen and Henrik Grönberg, thank you for making MEB such a wonderful place for research.

Past and present colleagues of the psychiatric epidemiology group at MEB: Alexander Viktorin, Amir Sariaslan, Barbro Sandin, Camilla Palm, Carl Sellgren, Charlotte Skoglund, Christina Hultman, Christina Norrby, Emma Frans, Erik Pettersson, Eva Noren-Selinus, Gunilla Hedlund, Iffat Rahman, Jie Song, Johan Zetterqvist, Karin Dellenvall, Lennart Martinsson, Marcus Boman, Maria Berner Holmström, Martin Cederlöf, Mikael Landén, Monica Sagerstål, Patrik Magnusson, Qi Chen, Sarah Bergen, Simon Kyaga, Therese Ljung, Thomas Frisell, Mats Forsman, Rozita Broumandi, Shuyang Yao, Volen Ivanov, and Ylva Ginsberg. You are really a bunch of smart and kind people. It has been a great pleasure working with you.

Past and present Chinese colleagues at MEB: Chen Suo, Donghao Lu, Fang Fang, Fei Yang, Haiyun Wang, He Gao, Huan Song, Jiangrong Wang, Jianwei Zhu, Jiaqi Huang, Li Yin, Ruoqing Chen, Tong Gong, Xingrong Liu, Zhiwei Liu, and Zongli Zheng. Thank you for the support, friendship and lots of fun during the years.

I would also like to thank to the TA-staff and IT/Data-staff at MEB for all the help during the years.

Anita Berglund and Eva Willis, thank you for organizing the SIMSAM research school.

Sebastian Lundström, thank you for the good collaborations and interesting talks.

Past and present Chinese friends in Sweden: Bin Zhao, Chan Shan, Chang Liu, Daohua Lou, Dong Yang, Heng Wang, Jianren Song, Juan Du, Junwei Zhang, Kai Du, Meiqiongzi Zhang, Na Guan, Ning Wang, Qiang Zhang, Qin Li, Qinzi Yan, Qiuling Huang, Shuo Liu, Sun Sun, Tian Li, Tiansheng Shi, Tianwei Gu, Xi Liu, Xiaoda Wang, Xiaoyuan Ren, Xinming Wang, Yang Xuan, Yao Shi, Yiqiao Wang, Yixin Wang, Yuan Xue, Yuning Zhang, Yunlong Yang, Zhili Song, Ziming Du, and friends in Switzerland: Jianpin Cheng and Qiang Lan. I am so lucky to be friends with you guys. It has been a time to remember.

Ci, thank you for every moment that we have been together. Life is colorful with you.

Finally, my family, thank you for the never-ending support and love.



## 10 REFERENCES

1. Palmer ED, Finger S. An Early Description of ADHD (Inattentive Subtype): Dr Alexander Crichton and 'Mental Restlessness' (1798). *Child and Adolescent Mental Health* May 2001;6(2):66-73.
2. Barkley RA. The relevance of the still lectures to attention-deficit/hyperactivity disorder: a commentary. *J Atten Disord.* Nov 2006;10(2):137-140.
3. Spencer TJ, Biederman J, Mick E. Attention-deficit/hyperactivity disorder: diagnosis, lifespan, comorbidities, and neurobiology. *J Pediatr Psychol.* Jul 2007;32(6):631-642.
4. Centers for Disease Control and Prevention. Timeline of ADHD diagnostic criteria, prevalence, and treatment. 2013. Accessed Sep 2, 2013.
5. American Psychiatric Association. *Diagnostic and statistical manual of mental disorders, 3rd ed., revised.* Washington. DC: American Psychiatric Association; 1987.
6. American Psychiatric Association. *Diagnostic and statistical manual of mental disorders, 4th ed.* Washington. DC: American Psychiatric Association; 1994.
7. American Psychiatric Association. *Diagnostic and statistical manual of mental disorders 5th ed.* Washington. DC: American Psychiatric Association; 2013.
8. World Health Organization. *ICD-10 Classifications of Mental and Behavioural Disorder: Clinical Descriptions and Diagnostic Guidelines.* Geneva: World Health Organisation;1992.
9. Lee SI, Schachar RJ, Chen SX, et al. Predictive validity of DSM-IV and ICD-10 criteria for ADHD and hyperkinetic disorder. *J Child Psychol Psychiatry.* Jan 2008;49(1):70-78.
10. Widiger TA, Samuel DB. Diagnostic categories or dimensions? A question for the Diagnostic And Statistical Manual Of Mental Disorders--fifth edition. *J Abnorm Psychol.* Nov 2005;114(4):494-504.
11. Brown TA, Barlow DH. Dimensional versus categorical classification of mental disorders in the fifth edition of the Diagnostic and Statistical Manual of Mental Disorders and beyond: comment on the special section. *J Abnorm Psychol.* Nov 2005;114(4):551-556.
12. Haslam N, Williams B, Prior M, Haslam R, Graetz B, Sawyer M. The latent structure of attention-deficit/hyperactivity disorder: a taxometric analysis. *Aust N Z J Psychiatry.* Aug 2006;40(8):639-647.
13. Larsson H, Anckarsater H, Rastam M, Chang Z, Lichtenstein P. Childhood attention-deficit hyperactivity disorder as an extreme of a continuous trait: a quantitative genetic study of 8,500 twin pairs. *J Child Psychol Psychiatry.* Jan 2012;53(1):73-80.
14. Collett BR, Ohan JL, Myers KM. Ten-year review of rating scales. V: scales assessing attention-deficit/hyperactivity disorder. *J Am Acad Child Adolesc Psychiatry.* Sep 2003;42(9):1015-1037.
15. Faraone SV, Sergeant J, Gillberg C, Biederman J. The worldwide prevalence of ADHD: is it an American condition? *World Psychiatry.* Jun 2003;2(2):104-113.
16. Polanczyk G, de Lima MS, Horta BL, Biederman J, Rohde LA. The worldwide prevalence of ADHD: a systematic review and metaregression analysis. *Am J Psychiatry.* Jun 2007;164(6):942-948.
17. Kessler RC, Adler L, Barkley R, et al. The prevalence and correlates of adult ADHD in the United States: results from the National Comorbidity Survey Replication. *Am J Psychiatry.* Apr 2006;163(4):716-723.
18. Simon V, Czobor P, Balint S, Meszaros A, Bitter I. Prevalence and correlates of adult attention-deficit hyperactivity disorder: meta-analysis. *Br J Psychiatry.* Mar 2009;194(3):204-211.

19. Gaub M, Carlson CL. Gender differences in ADHD: a meta-analysis and critical review. *J Am Acad Child Adolesc Psychiatry*. Aug 1997;36(8):1036-1045.
20. Biederman J, Mick E, Faraone SV, et al. Influence of gender on attention deficit hyperactivity disorder in children referred to a psychiatric clinic. *Am J Psychiatry*. Jan 2002;159(1):36-42.
21. Gershon J. A meta-analytic review of gender differences in ADHD. *J Atten Disord*. Jan 2002;5(3):143-154.
22. Centers for Disease Control and Prevention. *Increasing Prevalence of Parent-Reported Attention-Deficit/Hyperactivity Disorder Among Children --- United States, 2003 and 2007* 2010.
23. Centers for Disease Control and Prevention. Attention-Deficit / Hyperactivity Disorder (ADHD) Data & Statistics. 2013. Accessed Sep 3, 2013.
24. Schwarz A, Cohen S. A.D.H.D. Seen in 11% of U.S. Children as Diagnoses Rise. *The New York Times*. March 31, 2013 2013.
25. Scituito MJ, Eisenberg M. Evaluating the evidence for and against the overdiagnosis of ADHD. *J Atten Disord*. Sep 2007;11(2):106-113.
26. Biederman J, Petty CR, Clarke A, Lomedico A, Faraone SV. Predictors of persistent ADHD: an 11-year follow-up study. *J Psychiatr Res*. Feb 2011;45(2):150-155.
27. Biederman J, Petty CR, Evans M, Small J, Faraone SV. How persistent is ADHD? A controlled 10-year follow-up study of boys with ADHD. *Psychiatry Res*. May 30 2010;177(3):299-304.
28. Faraone SV, Biederman J, Mick E. The age-dependent decline of attention deficit hyperactivity disorder: a meta-analysis of follow-up studies. *Psychol Med*. Feb 2006;36(2):159-165.
29. American Psychiatric Association. *Diagnostic and statistical manual of mental disorders, 4th ed., text rev.* Washington. DC: American Psychiatric Association; 2000.
30. Wilens TE, Biederman J, Faraone SV, Martelon M, Westerberg D, Spencer TJ. Presenting ADHD symptoms, subtypes, and comorbid disorders in clinically referred adults with ADHD. *J Clin Psychiatry*. Nov 2009;70(11):1557-1562.
31. Biederman J, Mick E, Faraone SV. Age-dependent decline of symptoms of attention deficit hyperactivity disorder: impact of remission definition and symptom type. *Am J Psychiatry*. May 2000;157(5):816-818.
32. Larsson H, Dilshad R, Lichtenstein P, Barker ED. Developmental trajectories of DSM-IV symptoms of attention-deficit/hyperactivity disorder: genetic effects, family risk and associated psychopathology. *J Child Psychol Psychiatry*. Sep 2011;52(9):954-963.
33. Barkley RA. Major life activity and health outcomes associated with attention-deficit/hyperactivity disorder. *J Clin Psychiatry*. 2002;63 Suppl 12:10-15.
34. Wilens TE, Faraone SV, Biederman J. Attention-deficit/hyperactivity disorder in adults. *JAMA*. Aug 4 2004;292(5):619-623.
35. Barkley RA. Global issues related to the impact of untreated attention-deficit/hyperactivity disorder from childhood to young adulthood. *Postgrad Med*. Sep 2008;120(3):48-59.
36. Asherson P, Akehurst R, Kooij JJ, et al. Under diagnosis of adult ADHD: cultural influences and societal burden. *J Atten Disord*. Jul 2012;16(5 Suppl):20S-38S.
37. American Psychiatric Association. Highlight of Changes from DSM-IV-TR to DSM-5. 2013. <http://www.dsm5.org/Documents/changes%20from%20dsm-iv-tr%20to%20dsm-5.pdf>. Accessed Jul 28, 2013.
38. Giedd JN, Rapoport JL. Structural MRI of pediatric brain development: what have we learned and where are we going? *Neuron*. Sep 9 2010;67(5):728-734.
39. Purper-Ouakil D, Ramoz N, Lepagnol-Bestel AM, Gorwood P, Simonneau M. Neurobiology of attention deficit/hyperactivity disorder. *Pediatr Res*. May 2011;69(5 Pt 2):69R-76R.
40. Cubillo A, Halari R, Smith A, Taylor E, Rubia K. A review of fronto-striatal and fronto-cortical brain abnormalities in children and adults with Attention Deficit Hyperactivity Disorder (ADHD) and new evidence for dysfunction in

- adults with ADHD during motivation and attention. *Cortex*. Feb 2012;48(2):194-215.
41. Seidman LJ, Valera EM, Makris N. Structural brain imaging of attention-deficit/hyperactivity disorder. *Biological psychiatry*. Jun 1 2005;57(11):1263-1272.
  42. Valera EM, Faraone SV, Murray KE, Seidman LJ. Meta-analysis of structural imaging findings in attention-deficit/hyperactivity disorder. *Biological psychiatry*. Jun 15 2007;61(12):1361-1369.
  43. Shaw P, Eckstrand K, Sharp W, et al. Attention-deficit/hyperactivity disorder is characterized by a delay in cortical maturation. *Proc Natl Acad Sci U S A*. Dec 4 2007;104(49):19649-19654.
  44. Castellanos FX, Lee PP, Sharp W, et al. Developmental trajectories of brain volume abnormalities in children and adolescents with attention-deficit/hyperactivity disorder. *JAMA : the journal of the American Medical Association*. Oct 9 2002;288(14):1740-1748.
  45. Dickstein SG, Bannon K, Castellanos FX, Milham MP. The neural correlates of attention deficit hyperactivity disorder: an ALE meta-analysis. *J Child Psychol Psychiatry*. Oct 2006;47(10):1051-1062.
  46. Cortese S, Kelly C, Chabernaud C, et al. Toward systems neuroscience of ADHD: a meta-analysis of 55 fMRI studies. *Am J Psychiatry*. Oct 2012;169(10):1038-1055.
  47. Willcutt EG, Doyle AE, Nigg JT, Faraone SV, Pennington BF. Validity of the executive function theory of attention-deficit/hyperactivity disorder: a meta-analytic review. *Biological psychiatry*. Jun 1 2005;57(11):1336-1346.
  48. Barkley RA. Behavioral inhibition, sustained attention, and executive functions: constructing a unifying theory of ADHD. *Psychol Bull*. Jan 1997;121(1):65-94.
  49. Pennington BF, Ozonoff S. Executive functions and developmental psychopathology. *J Child Psychol Psychiatry*. Jan 1996;37(1):51-87.
  50. Sonuga-Barke EJ. The dual pathway model of AD/HD: an elaboration of neurodevelopmental characteristics. *Neurosci Biobehav Rev*. Nov 2003;27(7):593-604.
  51. Kooij SJ, Bejerot S, Blackwell A, et al. European consensus statement on diagnosis and treatment of adult ADHD: The European Network Adult ADHD. *BMC Psychiatry*. 2010;10:67.
  52. Russell VA. Overview of animal models of attention deficit hyperactivity disorder (ADHD). *Curr Protoc Neurosci*. Jan 2011;Chapter 9:Unit9 35.
  53. Cortese S. The neurobiology and genetics of Attention-Deficit/Hyperactivity Disorder (ADHD): what every clinician should know. *Eur J Paediatr Neurol*. Sep 2012;16(5):422-433.
  54. Biederman J, Faraone SV, Keenan K, Knee D, Tsuang MT. Family-genetic and psychosocial risk factors in DSM-III attention deficit disorder. *J Am Acad Child Adolesc Psychiatry*. Jul 1990;29(4):526-533.
  55. Faraone SV, Doyle AE. The nature and heritability of attention-deficit/hyperactivity disorder. *Child Adolesc Psychiatr Clin N Am*. Apr 2001;10(2):299-316, viii-ix.
  56. Frick PJ, Lahey BB, Christ MAG, Loeber R, Green S. History of Childhood Behavior Problems in Biological Relatives of Boys with Attention-Deficit Hyperactivity Disorder and Conduct Disorder. *J Clin Child Psychol*. Dec 1991;20(4):445-451.
  57. Faraone SV, Perlis RH, Doyle AE, et al. Molecular genetics of attention-deficit/hyperactivity disorder. *Biol Psychiatry*. Jun 1 2005;57(11):1313-1323.
  58. Plomin R, Defries JC, Knopik VS, Neiderhiser JM. *Behavioral genetics*. Sixth Edition ed. New York: Worth; 2013.
  59. Boomsma DI, Saviouk V, Hottenga JJ, et al. Genetic epidemiology of attention deficit hyperactivity disorder (ADHD index) in adults. *PLoS One*. 2010;5(5):e10621.
  60. Reiersen AM, Constantino JN, Grimmer M, Martin NG, Todd RD. Evidence for shared genetic influences on self-reported ADHD and autistic symptoms in young adult Australian twins. *Twin Res Hum Genet*. Dec 2008;11(6):579-585.

61. van den Berg SM, Willemsen G, de Geus EJ, Boomsma DI. Genetic etiology of stability of attention problems in young adulthood. *Am J Med Genet B Neuropsychiatr Genet.* Jan 5 2006;141B(1):55-60.
62. Larsson H, Asherson P, Chang Z, et al. Genetic and environmental influences on adult attention deficit hyperactivity disorder symptoms: a large Swedish population-based study of twins. *Psychological medicine.* Jan 2013;43(1):197-207.
63. Franke B, Faraone SV, Asherson P, et al. The genetics of attention deficit/hyperactivity disorder in adults, a review. *Mol Psychiatry.* Nov 22 2011.
64. Gizer IR, Ficks C, Waldman ID. Candidate gene studies of ADHD: a meta-analytic review. *Hum Genet.* Jul 2009;126(1):51-90.
65. Ebejer JL, Duffy DL, van der Werf J, et al. Genome-wide association study of inattention and hyperactivity-impulsivity measured as quantitative traits. *Twin research and human genetics : the official journal of the International Society for Twin Studies.* Apr 2013;16(2):560-574.
66. Hinney A, Scherag A, Jarick I, et al. Genome-wide association study in German patients with attention deficit/hyperactivity disorder. *Am J Med Genet B Neuropsychiatr Genet.* Dec 2011;156B(8):888-897.
67. Neale BM, Medland SE, Ripke S, et al. Meta-analysis of genome-wide association studies of attention-deficit/hyperactivity disorder. *J Am Acad Child Adolesc Psychiatry.* Sep 2010;49(9):884-897.
68. Williams NM, Franke B, Mick E, et al. Genome-wide analysis of copy number variants in attention deficit hyperactivity disorder: the role of rare variants and duplications at 15q13.3. *Am J Psychiatry.* Feb 2012;169(2):195-204.
69. Williams NM, Zaharieva I, Martin A, et al. Rare chromosomal deletions and duplications in attention-deficit hyperactivity disorder: a genome-wide analysis. *Lancet.* Oct 23 2010;376(9750):1401-1408.
70. Kendler KS. "A gene for...": the nature of gene action in psychiatric disorders. *Am J Psychiatry.* Jul 2005;162(7):1243-1252.
71. Thapar A, Cooper M, Eyre O, Langley K. What have we learnt about the causes of ADHD? *J Child Psychol Psychiatry.* Jan 2013;54(1):3-16.
72. Banerjee TD, Middleton F, Faraone SV. Environmental risk factors for attention-deficit hyperactivity disorder. *Acta Paediatr.* Sep 2007;96(9):1269-1274.
73. Lahey BB, D'Onofrio BM, Waldman ID. Using epidemiologic methods to test hypotheses regarding causal influences on child and adolescent mental disorders. *J Child Psychol Psychiatry.* Jan 2009;50(1-2):53-62.
74. Rutter M. Proceeding From Observed Correlation to Causal Inference The Use of Natural Experiments. *Perspect Psychol Sci.* Dec 2007;2(4):377-395.
75. Thapar A, Rutter M. Do prenatal risk factors cause psychiatric disorder? Be wary of causal claims. *Br J Psychiatry.* Aug 2009;195(2):100-101.
76. Rutter M. Psychosocial influences: critiques, findings, and research needs. *Development and psychopathology.* Summer 2000;12(3):375-405.
77. Moffitt TE. The new look of behavioral genetics in developmental psychopathology: gene-environment interplay in antisocial behaviors. *Psychol Bull.* Jul 2005;131(4):533-554.
78. O'Connor TG. Natural experiments to study the effects of early experience: progress and limitations. *Development and psychopathology.* Fall 2003;15(4):837-852.
79. Rutter M, Pickles A, Murray R, Eaves L. Testing hypotheses on specific environmental causal effects on behavior. *Psychol Bull.* May 2001;127(3):291-324.
80. Langley K, Rice F, van den Bree MB, Thapar A. Maternal smoking during pregnancy as an environmental risk factor for attention deficit hyperactivity disorder behaviour. A review. *Minerva Pediatr.* Dec 2005;57(6):359-371.
81. Lindblad F, Hjern A. ADHD after fetal exposure to maternal smoking. *Nicotine Tob Res.* Apr 2010;12(4):408-415.
82. Obel C, Olsen J, Henriksen TB, et al. Is maternal smoking during pregnancy a risk factor for hyperkinetic disorder?--Findings from a sibling design. *Int J Epidemiol.* Apr 2011;40(2):338-345.

83. Murphy KR, Barkley RA, Bush T. Young adults with attention deficit hyperactivity disorder: subtype differences in comorbidity, educational, and clinical history. *J Nerv Ment Dis.* Mar 2002;190(3):147-157.
84. Willcutt EG, Pennington BF, Chhabildas NA, Friedman MC, Alexander J. Psychiatric comorbidity associated with DSM-IV ADHD in a nonreferred sample of twins. *J Am Acad Child Adolesc Psychiatry.* Nov 1999;38(11):1355-1362.
85. Biederman J, Newcorn J, Sprich S. Comorbidity of attention deficit hyperactivity disorder with conduct, depressive, anxiety, and other disorders. *Am J Psychiatry.* May 1991;148(5):564-577.
86. Biederman J, Faraone SV. Attention-deficit hyperactivity disorder. *Lancet.* Jul 16-22 2005;366(9481):237-248.
87. Doshi JA, Hodgkins P, Kahle J, et al. Economic impact of childhood and adult attention-deficit/hyperactivity disorder in the United States. *J Am Acad Child Adolesc Psychiatry.* Oct 2012;51(10):990-1002 e1002.
88. Leibson CL, Katusic SK, Barbaresi WJ, Ransom J, O'Brien PC. Use and costs of medical care for children and adolescents with and without attention-deficit/hyperactivity disorder. *JAMA : the journal of the American Medical Association.* Jan 3 2001;285(1):60-66.
89. Pliszka SR. Comorbidity of attention-deficit/hyperactivity disorder with psychiatric disorder: an overview. *J Clin Psychiatry.* 1998;59 Suppl 7:50-58.
90. August GJ, Garfinkel BD. Comorbidity of ADHD and reading disability among clinic-referred children. *J Abnorm Child Psychol.* Feb 1990;18(1):29-45.
91. Kuntsi J, Eley TC, Taylor A, et al. Co-occurrence of ADHD and low IQ has genetic origins. *Am J Med Genet B Neuropsychiatr Genet.* Jan 1 2004;124B(1):41-47.
92. Lichtenstein P, Carlstrom E, Rastam M, Gillberg C, Anckarsater H. The genetics of autism spectrum disorders and related neuropsychiatric disorders in childhood. *Am J Psychiatry.* Nov 2010;167(11):1357-1363.
93. Ronald A, Larsson H, Anckarsater H, Lichtenstein P. A twin study of autism symptoms in Sweden. *Mol Psychiatry.* Oct 2011;16(10):1039-1047.
94. Wilens TE, Biederman J, Mick E. Does ADHD affect the course of substance abuse? Findings from a sample of adults with and without ADHD. *Am J Addict.* Spring 1998;7(2):156-163.
95. Elkins IJ, McGue M, Iacono WG. Prospective effects of attention-deficit/hyperactivity disorder, conduct disorder, and sex on adolescent substance use and abuse. *Arch Gen Psychiatry.* Oct 2007;64(10):1145-1152.
96. Molina BS, Pelham WE, Jr. Childhood predictors of adolescent substance use in a longitudinal study of children with ADHD. *J Abnorm Psychol.* Aug 2003;112(3):497-507.
97. Biederman J, Petty CR, Wilens TE, et al. Familial risk analyses of attention deficit hyperactivity disorder and substance use disorders. *Am J Psychiatry.* Jan 2008;165(1):107-115.
98. Krueger RF, Hicks BM, Patrick CJ, Carlson SR, Iacono WG, McGue M. Etiologic connections among substance dependence, antisocial behavior, and personality: modeling the externalizing spectrum. *J Abnorm Psychol.* Aug 2002;111(3):411-424.
99. Young SE, Stallings MC, Corley RP, Krauter KS, Hewitt JK. Genetic and environmental influences on behavioral disinhibition. *Am J Med Genet.* Oct 9 2000;96(5):684-695.
100. Loe IM, Feldman HM. Academic and educational outcomes of children with ADHD. *J Pediatr Psychol.* Jul 2007;32(6):643-654.
101. Faraone SV, Biederman J, Lehman BK, et al. Intellectual performance and school failure in children with attention deficit hyperactivity disorder and in their siblings. *J Abnorm Psychol.* Nov 1993;102(4):616-623.
102. DuPaul GJ, McGoey KE, Eckert TL, VanBrakle J. Preschool children with attention-deficit/hyperactivity disorder: impairments in behavioral, social, and school functioning. *J Am Acad Child Adolesc Psychiatry.* May 2001;40(5):508-515.

103. Shilon Y, Pollak Y, Aran A, Shaked S, Gross-Tsur V. Accidental injuries are more common in children with attention deficit hyperactivity disorder compared with their non-affected siblings. *Child Care Health Dev.* May 2012;38(3):366-370.
104. DiScala C, Lescohier I, Barthel M, Li G. Injuries to children with attention deficit hyperactivity disorder. *Pediatrics.* Dec 1998;102(6):1415-1421.
105. Biederman J, Faraone SV, Spencer TJ, Mick E, Monuteaux MC, Aleardi M. Functional impairments in adults with self-reports of diagnosed ADHD: A controlled study of 1001 adults in the community. *J Clin Psychiatry.* Apr 2006;67(4):524-540.
106. Barkley RA. Driving impairments in teens and adults with attention-deficit/hyperactivity disorder. *Psychiatr Clin North Am.* Jun 2004;27(2):233-260.
107. Barkley RA, Cox D. A review of driving risks and impairments associated with attention-deficit/hyperactivity disorder and the effects of stimulant medication on driving performance. *J Safety Res.* 2007;38(1):113-128.
108. Jerome L, Habinski L, Segal A. Attention-deficit/hyperactivity disorder (ADHD) and driving risk: a review of the literature and a methodological critique. *Curr Psychiatry Rep.* Oct 2006;8(5):416-426.
109. Fabiano GA, Pelham WE, Jr., Coles EK, Gnagy EM, Chronis-Tuscano A, O'Connor BC. A meta-analysis of behavioral treatments for attention-deficit/hyperactivity disorder. *Clin Psychol Rev.* Mar 2009;29(2):129-140.
110. Sonuga-Barke EJ, Brandeis D, Cortese S, et al. Nonpharmacological interventions for ADHD: systematic review and meta-analyses of randomized controlled trials of dietary and psychological treatments. *Am J Psychiatry.* Mar 1 2013;170(3):275-289.
111. Safren SA, Otto MW, Sprich S, Winett CL, Wilens TE, Biederman J. Cognitive-behavioral therapy for ADHD in medication-treated adults with continued symptoms. *Behav Res Ther.* Jul 2005;43(7):831-842.
112. Wilens TE, Biederman J, Spencer TJ. Attention deficit/hyperactivity disorder across the lifespan. *Annu Rev Med.* 2002;53:113-131.
113. Hanwella R, Senanayake M, de Silva V. Comparative efficacy and acceptability of methylphenidate and atomoxetine in treatment of attention deficit hyperactivity disorder in children and adolescents: a meta-analysis. *BMC Psychiatry.* 2011;11:176.
114. Faraone SV, Biederman J, Spencer TJ, Aleardi M. Comparing the efficacy of medications for ADHD using meta-analysis. *MedGenMed.* 2006;8(4):4.
115. Adler LA, Zimmerman B, Starr HL, et al. Efficacy and safety of OROS methylphenidate in adults with attention-deficit/hyperactivity disorder: a randomized, placebo-controlled, double-blind, parallel group, dose-escalation study. *J Clin Psychopharmacol.* Jun 2009;29(3):239-247.
116. Banaschewski T, Coghill D, Santosh P, et al. Long-acting medications for the hyperkinetic disorders. A systematic review and European treatment guideline. *Eur Child Adolesc Psychiatry.* Dec 2006;15(8):476-495.
117. Findling RL, Bukstein OG, Melmed RD, et al. A randomized, double-blind, placebo-controlled, parallel-group study of methylphenidate transdermal system in pediatric patients with attention-deficit/hyperactivity disorder. *J Clin Psychiatry.* Jan 2008;69(1):149-159.
118. Newcorn JH, Kratochvil CJ, Allen AJ, et al. Atomoxetine and osmotically released methylphenidate for the treatment of attention deficit hyperactivity disorder: acute comparison and differential response. *Am J Psychiatry.* Jun 2008;165(6):721-730.
119. Svanborg P, Thernlund G, Gustafsson PA, Hagglof B, Poole L, Kadesjo B. Efficacy and safety of atomoxetine as add-on to psychoeducation in the treatment of attention deficit/hyperactivity disorder: a randomized, double-blind, placebo-controlled study in stimulant-naive Swedish children and adolescents. *Eur Child Adolesc Psychiatry.* Apr 2009;18(4):240-249.
120. Young JL, Sarkis E, Qiao M, Wietecha L. Once-daily treatment with atomoxetine in adults with attention-deficit/hyperactivity disorder: a 24-week,

- randomized, double-blind, placebo-controlled trial. *Clin Neuropharmacol.* Mar-Apr 2011;34(2):51-60.
121. Group TMC. A 14-month randomized clinical trial of treatment strategies for attention-deficit/hyperactivity disorder. The MTA Cooperative Group. Multimodal Treatment Study of Children with ADHD. *Arch Gen Psychiatry.* Dec 1999;56(12):1073-1086.
  122. Lichtenstein P, Halldner L, Zetterqvist J, et al. Medication for attention deficit-hyperactivity disorder and criminality. *N Engl J Med.* Nov 22 2012;367(21):2006-2014.
  123. Singh I. Beyond polemics: science and ethics of ADHD. *Nat Rev Neurosci.* Dec 2008;9(12):957-964.
  124. Graham J, Coghill D. Adverse effects of pharmacotherapies for attention-deficit hyperactivity disorder: epidemiology, prevention and management. *CNS Drugs.* 2008;22(3):213-237.
  125. Gibbons RD, Amatya AK, Brown CH, et al. Post-approval drug safety surveillance. *Annu Rev Public Health.* 2010;31:419-437.
  126. Adler LD, Nierenberg AA. Review of medication adherence in children and adults with ADHD. *Postgraduate medicine.* Jan 2010;122(1):184-191.
  127. Zetterqvist J, Asherson P, Halldner L, Langstrom N, Larsson H. Stimulant and non-stimulant attention deficit/hyperactivity disorder drug use: total population study of trends and discontinuation patterns 2006-2009. *Acta Psychiatr Scand.* Sep 4 2012.
  128. Castle L, Aubert RE, Verbrugge RR, Khalid M, Epstein RS. Trends in medication treatment for ADHD. *J Atten Disord.* May 2007;10(4):335-342.
  129. Zoega H, Furu K, Halldorsson M, Thomsen PH, Sourander A, Martikainen JE. Use of ADHD drugs in the Nordic countries: a population-based comparison study. *Acta Psychiatr Scand.* May 2011;123(5):360-367.
  130. Ray WA. Population-based studies of adverse drug effects. *N Engl J Med.* Oct 23 2003;349(17):1592-1594.
  131. Rawlins M. De testimonio: on the evidence for decisions about the use of therapeutic interventions. *Lancet.* Dec 20 2008;372(9656):2152-2161.
  132. Merwood A, Greven CU, Price TS, et al. Different heritabilities but shared etiological influences for parent, teacher and self-ratings of ADHD symptoms: an adolescent twin study. *Psychological medicine.* Sep 2013;43(9):1973-1984.
  133. Faraone SV. Genetics of adult attention-deficit/hyperactivity disorder. *Psychiatr Clin North Am.* Jun 2004;27(2):303-321.
  134. Larsson H, Lichtenstein P, Larsson JO. Genetic contributions to the development of ADHD subtypes from childhood to adolescence. *J Am Acad Child Adolesc Psychiatry.* Aug 2006;45(8):973-981.
  135. Kuntsi J, Rijdsdijk F, Ronald A, Asherson P, Plomin R. Genetic influences on the stability of attention-deficit/hyperactivity disorder symptoms from early to middle childhood. *Biol Psychiatry.* Mar 15 2005;57(6):647-654.
  136. Price TS, Simonoff E, Asherson P, et al. Continuity and change in preschool ADHD symptoms: longitudinal genetic analysis with contrast effects. *Behav Genet.* Mar 2005;35(2):121-132.
  137. Rietveld MJ, Hudziak JJ, Bartels M, van Beijsterveldt CE, Boomsma DI. Heritability of attention problems in children: longitudinal results from a study of twins, age 3 to 12. *J Child Psychol Psychiatry.* Mar 2004;45(3):577-588.
  138. Coyne CA, D'Onofrio BM. Some (but not much) progress toward understanding teenage childbearing: a review of research from the past decade. *Adv Child Dev Behav.* 2012;42:113-152.
  139. Coyne CA, Langstrom N, Rickert ME, Lichtenstein P, D'Onofrio BM. Maternal age at first birth and offspring criminality: using the children of twins design to test causal hypotheses. *Development and psychopathology.* Feb 2013;25(1):17-35.
  140. D'Onofrio BM, Goodnight JA, Van Hulle CA, et al. Maternal age at childbirth and offspring disruptive behaviors: testing the causal hypothesis. *J Child Psychol Psychiatry.* Aug 2009;50(8):1018-1028.
  141. Spencer TJ. ADHD and comorbidity in childhood. *J Clin Psychiatry.* 2006;67 Suppl 8:27-31.

142. Dick DM, Viken RJ, Kaprio J, Pulkkinen L, Rose RJ. Understanding the covariation among childhood externalizing symptoms: genetic and environmental influences on conduct disorder, attention deficit hyperactivity disorder, and oppositional defiant disorder symptoms. *J Abnorm Child Psychol*. Apr 2005;33(2):219-229.
143. Galera C, Cote SM, Bouvard MP, et al. Early risk factors for hyperactivity-impulsivity and inattention trajectories from age 17 months to 8 years. *Arch Gen Psychiatry*. Dec 2011;68(12):1267-1275.
144. Gustafsson P, Kallen K. Perinatal, maternal, and fetal characteristics of children diagnosed with attention-deficit-hyperactivity disorder: results from a population-based study utilizing the Swedish Medical Birth Register. *Dev Med Child Neurol*. Mar 2011;53(3):263-268.
145. Jaffee S, Caspi A, Moffitt TE, Belsky J, Silva P. Why are children born to teen mothers at risk for adverse outcomes in young adulthood? Results from a 20-year longitudinal study. *Development and psychopathology*. Spring 2001;13(2):377-397.
146. Jaffee SR, Price TS. Gene-environment correlations: a review of the evidence and implications for prevention of mental illness. *Mol Psychiatry*. May 2007;12(5):432-442.
147. Plomin R, DeFries JC, Loehlin JC. Genotype-environment interaction and correlation in the analysis of human behavior. *Psychol Bull*. Mar 1977;84(2):309-322.
148. Flory K, Lynam DR. The relation between attention deficit hyperactivity disorder and substance abuse: what role does conduct disorder play? *Clin Child Fam Psychol Rev*. Mar 2003;6(1):1-16.
149. Burke JD, Loeber R, Lahey BB. Which aspects of ADHD are associated with tobacco use in early adolescence? *J Child Psychol Psychiatry*. May 2001;42(4):493-502.
150. Burke JD, Loeber R, White HR, Stouthamer-Loeber M, Pardini DA. Inattention as a key predictor of tobacco use in adolescence. *J Abnorm Psychol*. May 2007;116(2):249-259.
151. Milberger S, Biederman J, Faraone SV, Chen L, Jones J. ADHD is associated with early initiation of cigarette smoking in children and adolescents. *J Am Acad Child Adolesc Psychiatry*. Jan 1997;36(1):37-44.
152. Gehricke JG, Loughlin SE, Whalen CK, et al. Smoking to self-medicate attentional and emotional dysfunctions. *Nicotine Tob Res*. Nov 2007;9 Suppl 4:S523-536.
153. Khantzian EJ. The self-medication hypothesis of substance use disorders: a reconsideration and recent applications. *Harv Rev Psychiatry*. Jan-Feb 1997;4(5):231-244.
154. Hopfer CJ, Crowley TJ, Hewitt JK. Review of twin and adoption studies of adolescent substance use. *J Am Acad Child Adolesc Psychiatry*. Jun 2003;42(6):710-719.
155. McGue M, Iacono WG. The association of early adolescent problem behavior with adult psychopathology. *Am J Psychiatry*. Jun 2005;162(6):1118-1124.
156. McGue M, Iacono WG, Legrand LN, Elkins I. Origins and consequences of age at first drink. II. Familial risk and heritability. *Alcohol Clin Exp Res*. Aug 2001;25(8):1166-1173.
157. WHO. Global status report on road safety: time for action. June 15, 2009 ed: [http://whqlibdoc.who.int/publications/2009/9789241563840\\_eng.pdf](http://whqlibdoc.who.int/publications/2009/9789241563840_eng.pdf). Accessed April 11, 2013.
158. Cox DJ, Cox BS, Cox J. Self-reported incidences of moving vehicle collisions and citations among drivers with ADHD: a cross-sectional survey across the lifespan. *Am J Psychiatry*. Mar 2011;168(3):329-330.
159. Cox DJ, Madaan V, Cox BS. Adult attention-deficit/hyperactivity disorder and driving: why and how to manage it. *Curr Psychiatry Rep*. Oct 2011;13(5):345-350.
160. Redelmeier DA, Chan WK, Lu H. Road trauma in teenage male youth with childhood disruptive behavior disorders: a population based analysis. *PLoS Med*. 2010;7(11):e1000369.



161. Biederman J, Fried R, Hammerness P, et al. The effects of lisdexamfetamine dimesylate on the driving performance of young adults with ADHD: a randomized, double-blind, placebo-controlled study using a validated driving simulator paradigm. *Journal of psychiatric research*. Apr 2012;46(4):484-491.
162. Fredriksen M, Halmoy A, Faraone SV, Haavik J. Long-term efficacy and safety of treatment with stimulants and atomoxetine in adult ADHD: A review of controlled and naturalistic studies. *Eur Neuropsychopharmacol*. Aug 20 2012.
163. Humphreys KL, Eng T, Lee SS. Stimulant Medication and Substance Use Outcomes: A Meta-analysis. *JAMA Psychiatry*. Jul 2013;70(7):740-749.
164. Winhusen TM, Lewis DF, Riggs PD, et al. Subjective effects, misuse, and adverse effects of osmotic-release methylphenidate treatment in adolescent substance abusers with attention-deficit/hyperactivity disorder. *J Child Adolesc Psychopharmacol*. Oct 2011;21(5):455-463.
165. Klein RG, Mannuzza S, Olazagasti MA, et al. Clinical and Functional Outcome of Childhood Attention-Deficit/Hyperactivity Disorder 33 Years Later. *Arch Gen Psychiatry*. Dec 2012;69(12):1295-1303.
166. Piazza PV, Deminiere JM, le Moal M, Simon H. Stress- and pharmacologically-induced behavioral sensitization increases vulnerability to acquisition of amphetamine self-administration. *Brain Res*. Apr 23 1990;514(1):22-26.
167. Schenk S, Partridge B. Sensitization and tolerance in psychostimulant self-administration. *Pharmacol Biochem Behav*. Jul 1997;57(3):543-550.
168. Barkley RA, Fischer M, Smallish L, Fletcher K. Does the treatment of attention-deficit/hyperactivity disorder with stimulants contribute to drug use/abuse? A 13-year prospective study. *Pediatrics*. Jan 2003;111(1):97-109.
169. Biederman J, Monuteaux MC, Spencer T, Wilens TE, Macpherson HA, Faraone SV. Stimulant therapy and risk for subsequent substance use disorders in male adults with ADHD: a naturalistic controlled 10-year follow-up study. *Am J Psychiatry*. May 2008;165(5):597-603.
170. Faraone SV, Wilens TE. Effect of stimulant medications for attention-deficit/hyperactivity disorder on later substance use and the potential for stimulant misuse, abuse, and diversion. *J Clin Psychiatry*. 2007;68 Suppl 11:15-22.
171. Wilens TE, Faraone SV, Biederman J, Gunawardene S. Does stimulant therapy of attention-deficit/hyperactivity disorder beget later substance abuse? A meta-analytic review of the literature. *Pediatrics*. Jan 2003;111(1):179-185.
172. Mannuzza S, Klein RG, Truong NL, et al. Age of methylphenidate treatment initiation in children with ADHD and later substance abuse: prospective follow-up into adulthood. *Am J Psychiatry*. May 2008;165(5):604-609.
173. Lichtenstein P, Tuvblad C, Larsson H, Carlstrom E. The Swedish Twin study of CHild and Adolescent Development: the TCHAD-study. *Twin Res Hum Genet*. Feb 2007;10(1):67-73.
174. Lichtenstein P, De Faire U, Floderus B, Svartengren M, Svedberg P, Pedersen NL. The Swedish Twin Registry: a unique resource for clinical, epidemiological and genetic studies. *J Intern Med*. Sep 2002;252(3):184-205.
175. Larsson JO, Larsson H, Lichtenstein P. Genetic and environmental contributions to stability and change of ADHD symptoms between 8 and 13 years of age: a longitudinal twin study. *J Am Acad Child Adolesc Psychiatry*. Oct 2004;43(10):1267-1275.
176. Forsman M, Larsson H, Andershed H, Lichtenstein P. The association between persistent disruptive childhood behaviour and the psychopathic personality constellation in adolescence: A twin study. *British Journal of Developmental Psychology*. 2007;25:383-398.
177. Achenbach TM. *Manual for the child behavior Checklist/4-18 and 1991 Profile*. Burlington, VT: University of Vermont, Department of Psychiatry; 1991.
178. Achenbach TM, Rescorla LA. *Manual for the ASEBA Adult Forms and Profiles*. Burlington, VT: University of Vermont, Research Center for Children, Youth and Families; 2003.

179. Achenbach TM. *Manual for the Youth Self-report and 1991 Profile*. Burlington, VT: University of Vermont, Department of Psychiatry; 1991.
180. Biederman J, Wozniak J, Kiely K, et al. CBCL clinical scales discriminate prepubertal children with structured interview-derived diagnosis of mania from those with ADHD. *J Am Acad Child Adolesc Psychiatry*. Apr 1995;34(4):464-471.
181. Derks EM, Hudziak JJ, Dolan CV, van Beijsterveldt TC, Verhulst FC, Boomsma DI. Genetic and environmental influences on the relation between attention problems and attention deficit hyperactivity disorder. *Behav Genet*. Jan 2008;38(1):11-23.
182. Hudziak JJ, Copeland W, Stanger C, Wadsworth M. Screening for DSM-IV externalizing disorders with the Child Behavior Checklist: a receiver-operating characteristic analysis. *J Child Psychol Psychiatry*. Oct 2004;45(7):1299-1307.
183. Achenbach TM, Dumenci L, Rescorla LA. DSM-oriented and empirically based approaches to constructing scales from the same item pools. *J Clin Child Adolesc Psychol*. Sep 2003;32(3):328-340.
184. Biederman J, Faraone SV, Doyle A, et al. Convergence of the Child Behavior Checklist with structured interview-based psychiatric diagnoses of ADHD children with and without comorbidity. *J Child Psychol Psychiatry*. Oct 1993;34(7):1241-1251.
185. Nakamura BJ, Ebesutani C, Bernstein A, Chorpita BF. A Psychometric Analysis of the Child Behavior Checklist DSM-Oriented Scales. *J Psychopathol Behav Assess*. 2009;31(3):178-189.
186. Eley TC, Lichtenstein P, Moffitt TE. A longitudinal behavioral genetic analysis of the etiology of aggressive and nonaggressive antisocial behavior. *Dev Psychopathol*. Spring 2003;15(2):383-402.
187. Ludvigsson JF, Otterblad-Olausson P, Pettersson BU, Ekblom A. The Swedish personal identity number: possibilities and pitfalls in healthcare and medical research. *Eur J Epidemiol*. 2009;24(11):659-667.
188. Statistics Sweden. *Multi-generation register 2005 - A description of contents and quality*. Örebro: Statistics Sweden; 2006.
189. Swedish National Board of Health and Welfare. *The Swedish Medical Birth Register: a summary of content and quality*. Stockholm: Swedish National Board of Health and Welfare; 2003.
190. Wettermark B, Hammar N, Fored CM, et al. The new Swedish Prescribed Drug Register--opportunities for pharmacoepidemiological research and experience from the first six months. *Pharmacoepidemiol Drug Saf*. Jul 2007;16(7):726-735.
191. Galton F. The history of twins, as a criterion of the relative powers of nature and nurture (1,2). *Int J Epidemiol*. Aug 2012;41(4):905-911.
192. Martin NG, Eaves LJ. The genetical analysis of covariance structure. *Heredity (Edinb)*. Feb 1977;38(1):79-95.
193. Rijdsdijk FV, Sham PC. Analytic approaches to twin data using structural equation models. *Brief Bioinform*. Jun 2002;3(2):119-133.
194. Neale MC, Boker SM, Xie G, Maes HH. *Mx: statistical modeling*. 6th ed. ed. VA: Department of Psychiatry; Richmond; 2003.
195. Boker S, Neale M, Maes H, et al. OpenMx: An Open Source Extended Structural Equation Modeling Framework. *Psychometrika*. Apr 1 2011;76(2):306-317.
196. Markon KE, Krueger RF. An empirical comparison of information-theoretic selection criteria for multivariate behavior genetic models. *Behav Genet*. Nov 2004;34(6):593-610.
197. Lahey BB, D'Onofrio BM. All in the Family: Comparing Siblings to Test Causal Hypotheses Regarding Environmental Influences on Behavior. *Curr Dir Psychol Sci*. Oct 2010;19(5):319-323.
198. Allison PD. *Fixed Effects Regression Models* SAGE Publications; 2009.
199. Frisell T, Oberg S, Kuja-Halkola R, Sjolander A. Sibling comparison designs: bias from non-shared confounders and measurement error. *Epidemiology*. Sep 2012;23(5):713-720.

200. Kendler KS, Gardner CO, Lichtenstein P. A developmental twin study of symptoms of anxiety and depression: evidence for genetic innovation and attenuation. *Psychol Med*. Nov 2008;38(11):1567-1575.
201. Muthén LK, Muthén BO. *Mplus User's Guide*. Fourth Edition ed. Los Angeles, CA: Muthén & Muthén; 1998-2006.
202. Kaprio J, Pulkkinen L, Rose RJ. Genetic and environmental factors in health-related behaviors: studies on Finnish twins and twin families. *Twin Res*. Oct 2002;5(5):366-371.
203. McCarthy S, Asherson P, Coghill D, et al. Attention-deficit hyperactivity disorder: treatment discontinuation in adolescents and young adults. *Br J Psychiatry*. Mar 2009;194(3):273-277.
204. Polanczyk G, Rohde LA. Epidemiology of attention-deficit/hyperactivity disorder across the lifespan. *Curr Opin Psychiatry*. Jul 2007;20(4):386-392.
205. Massie DL, Campbell KL, Williams AF. Traffic accident involvement rates by driver age and gender. *Accid Anal Prev*. Feb 1995;27(1):73-87.
206. Toroyan T, Peden M. *Youth and Road Safety*. Geneva: World Health Organization; 2007.
207. Kendler KS, Sundquist K, Ohlsson H, et al. Genetic and familial environmental influences on the risk for drug abuse: a national Swedish adoption study. *Arch Gen Psychiatry*. Jul 2012;69(7):690-697.
208. Biederman J, Petty CR, Ten Haagen KS, et al. Effect of candidate gene polymorphisms on the course of attention deficit hyperactivity disorder. *Psychiatry Res*. Dec 30 2009;170(2-3):199-203.
209. Johansson S, Halleland H, Halmoy A, et al. Genetic analyses of dopamine related genes in adult ADHD patients suggest an association with the DRD5-microsatellite repeat, but not with DRD4 or SLC6A3 VNTRs. *Am J Med Genet B Neuropsychiatr Genet*. Dec 5 2008;147B(8):1470-1475.
210. Ribases M, Hervas A, Ramos-Quiroga JA, et al. Association study of 10 genes encoding neurotrophic factors and their receptors in adult and child attention-deficit/hyperactivity disorder. *Biol Psychiatry*. May 15 2008;63(10):935-945.
211. Thapar A, Langley K, Asherson P, Gill M. Gene-environment interplay in attention-deficit hyperactivity disorder and the importance of a developmental perspective. *Br J Psychiatry*. Jan 2007;190:1-3.
212. Achenbach TM, Bernstein A, Dumenci L. DSM-oriented scales and statistically based syndromes for ages 18 to 59: linking taxonomic paradigms to facilitate multitaxonomic approaches. *J Pers Assess*. Feb 2005;84(1):49-63.
213. Turley RN. Are children of young mothers disadvantaged because of their mother's age or family background? *Child Dev*. Mar-Apr 2003;74(2):465-474.
214. Burt SA. Rethinking environmental contributions to child and adolescent psychopathology: a meta-analysis of shared environmental influences. *Psychol Bull*. Jul 2009;135(4):608-637.
215. Iacono WG, Malone SM, McGue M. Behavioral disinhibition and the development of early-onset addiction: common and specific influences. *Annu Rev Clin Psychol*. 2008;4:325-348.
216. Flory K, Lynam D, Milich R, Leukefeld C, Clayton R. Early adolescent through young adult alcohol and marijuana use trajectories: early predictors, young adult outcomes, and predictive utility. *Dev Psychopathol*. Winter 2004;16(1):193-213.
217. Kendler KS, Schmitt E, Aggen SH, Prescott CA. Genetic and environmental influences on alcohol, caffeine, cannabis, and nicotine use from early adolescence to middle adulthood. *Arch Gen Psychiatry*. Jun 2008;65(6):674-682.
218. Clark DB, Jones BL, Wood DS, Cornelius JR. Substance use disorder trajectory classes: diachronic integration of onset age, severity, and course. *Addict Behav*. Jun 2006;31(6):995-1009.
219. Costello DM, Dierker LC, Jones BL, Rose JS. Trajectories of smoking from adolescence to early adulthood and their psychosocial risk factors. *Health Psychol*. Nov 2008;27(6):811-818.

220. Marti CN, Stice E, Springer DW. Substance use and abuse trajectories across adolescence: a latent trajectory analysis of a community-recruited sample of girls. *J Adolesc.* Jun 2010;33(3):449-461.
221. McClernon FJ, Kollins SH. ADHD and smoking: from genes to brain to behavior. *Ann N Y Acad Sci.* Oct 2008;1141:131-147.
222. Barkley RA, Murphy KR, Dupaul GI, Bush T. Driving in young adults with attention deficit hyperactivity disorder: knowledge, performance, adverse outcomes, and the role of executive functioning. *J Int Neuropsychol Soc.* Jul 2002;8(5):655-672.
223. Cox DJ, Davis M, Mikami AY, Singh H, Merkel RL, Burket R. Long-acting methylphenidate reduces collision rates of young adult drivers with attention-deficit/hyperactivity disorder. *J Clin Psychopharmacol.* Apr 2012;32(2):225-230.
224. Mannuzza S, Klein RG, Moulton JL, 3rd. Does stimulant treatment place children at risk for adult substance abuse? A controlled, prospective follow-up study. *J Child Adolesc Psychopharmacol.* Fall 2003;13(3):273-282.
225. Fischer M, Barkley RA. Childhood stimulant treatment and risk for later substance abuse. *J Clin Psychiatry.* 2003;64 Suppl 11:19-23.
226. Nissen SE. ADHD drugs and cardiovascular risk. *N Engl J Med.* Apr 6 2006;354(14):1445-1448.
227. Bangs ME, Tauscher-Wisniewski S, Polzer J, et al. Meta-analysis of suicide-related behavior events in patients treated with atomoxetine. *J Am Acad Child Adolesc Psychiatry.* Feb 2008;47(2):209-218.
228. Wilens TE, Adler LA, Adams J, et al. Misuse and diversion of stimulants prescribed for ADHD: a systematic review of the literature. *J Am Acad Child Adolesc Psychiatry.* Jan 2008;47(1):21-31.
229. Larsson H, Ryden E, Boman M, Langstrom N, Lichtenstein P, Landen M. Risk of bipolar disorder and schizophrenia in relatives of people with attention-deficit hyperactivity disorder. *Br J Psychiatry.* Aug 2013;203:103-106.
230. Williams RJ, Nowatzki N. Validity of adolescent self-report of substance use. *Subst Use Misuse.* 2005;40(3):299-311.
231. Fisher SL, Bucholz KK, Reich W, et al. Teenagers are right--parents do not know much: an analysis of adolescent-parent agreement on reports of adolescent substance use, abuse, and dependence. *Alcohol Clin Exp Res.* Oct 2006;30(10):1699-1710.
232. Miguel H, Robins J. Causal Inference Chapman & Hall/CRC; 2013: <http://www.hsph.harvard.edu/miguel-hernan/causal-inference-book/>.
233. Lawlor DA, Harbord RM, Sterne JA, Timpson N, Davey Smith G. Mendelian randomization: using genes as instruments for making causal inferences in epidemiology. *Stat Med.* Apr 15 2008;27(8):1133-1163.
234. Plomin R, Defries JC, McClearn GE, McGuffin P. *Behavioral genetics.* 5th ed. ed. New York: Worth; 2008.
235. Cronk NJ, Slutske WS, Madden PA, Bucholz KK, Reich W, Heath AC. Emotional and behavioral problems among female twins: an evaluation of the equal environments assumption. *J Am Acad Child Adolesc Psychiatry.* Jul 2002;41(7):829-837.
236. Kendler KS, Neale MC, Kessler RC, Heath AC, Eaves LJ. A test of the equal-environment assumption in twin studies of psychiatric illness. *Behavior genetics.* Jan 1993;23(1):21-27.
237. Thapar A, Langley K, Asherson P, Gill M. Gene-environment interplay in attention-deficit hyperactivity disorder and the importance of a developmental perspective. *Br J Psychiatry.* Jan 2007;190:1-3.
238. Rutter M, Thorpe K, Greenwood R, Northstone K, Golding J. Twins as a natural experiment to study the causes of mild language delay: I: Design; twin-singleton differences in language, and obstetric risks. *J Child Psychol Psychiatry.* Mar 2003;44(3):326-341.
239. Rutter M, Redshaw J. Annotation: growing up as a twin: twin-singleton differences in psychological development. *J Child Psychol Psychiatry.* Sep 1991;32(6):885-895.

240. Andrew T, Hart DJ, Snieder H, de Lange M, Spector TD, MacGregor AJ. Are twins and singletons comparable? A study of disease-related and lifestyle characteristics in adult women. *Twin research : the official journal of the International Society for Twin Studies*. Dec 2001;4(6):464-477.
241. Moilanen I, Linna SL, Ebeling H, et al. Are twins' behavioural/emotional problems different from singletons'? *Eur Child Adolesc Psychiatry*. 1999;8 Suppl 4:62-67.
242. Larsson JO, Lichtenstein P, Fried I, El-Sayed E, Rydelius PA. Parents' perception of mental development and behavioural problems in 8 to 9-year-old children. *Acta Paediatr*. Dec 2000;89(12):1469-1473.
243. Eley TC, Lichtenstein P, Moffitt TE. A longitudinal behavioral genetic analysis of the etiology of aggressive and nonaggressive antisocial behavior. *Development and psychopathology*. Spring 2003;15(2):383-402.
244. Andrews G, Pine DS, Hobbs MJ, Anderson TM, Sunderland M. Neurodevelopmental disorders: cluster 2 of the proposed meta-structure for DSM-V and ICD-11. *Psychological medicine*. Dec 2009;39(12):2013-2023.
245. National Institute of Public Health. Alcohol Statistics 2007 Östersund, Sweden 2008.
246. van Dongen J, Slagboom PE, Draisma HH, Martin NG, Boomsma DI. The continuing value of twin studies in the omics era. *Nat Rev Genet*. Sep 2012;13(9):640-653.
247. Fraga MF, Ballestar E, Paz MF, et al. Epigenetic differences arise during the lifetime of monozygotic twins. *Proc Natl Acad Sci U S A*. Jul 26 2005;102(30):10604-10609.
248. Visscher PM, Medland SE, Ferreira MA, et al. Assumption-free estimation of heritability from genome-wide identity-by-descent sharing between full siblings. *PLoS Genet*. Mar 2006;2(3):e41.
249. Yang J, Benyamin B, McEvoy BP, et al. Common SNPs explain a large proportion of the heritability for human height. *Nat Genet*. Jul 2010;42(7):565-569.
250. Purcell SM, Wray NR, Stone JL, et al. Common polygenic variation contributes to risk of schizophrenia and bipolar disorder. *Nature*. Aug 6 2009;460(7256):748-752.
251. Dick DM, Rose RJ, Kaprio J. The next challenge for psychiatric genetics: characterizing the risk associated with identified genes. *Ann Clin Psychiatry*. Oct-Dec 2006;18(4):223-231.
252. Gottesman, II, Gould TD. The endophenotype concept in psychiatry: etymology and strategic intentions. *Am J Psychiatry*. Apr 2003;160(4):636-645.
253. Doyle AE, Willcutt EG, Seidman LJ, et al. Attention-deficit/hyperactivity disorder endophenotypes. *Biological psychiatry*. Jun 1 2005;57(11):1324-1335.
254. Posthuma D, Polderman TJ. What have we learned from recent twin studies about the etiology of neurodevelopmental disorders? *Curr Opin Neurol*. Apr 2013;26(2):111-121.
255. Kim-Cohen J, Caspi A, Taylor A, et al. MAOA, maltreatment, and gene-environment interaction predicting children's mental health: new evidence and a meta-analysis. *Mol Psychiatry*. Oct 2006;11(10):903-913.
256. Todd RD, Neuman RJ. Gene-environment interactions in the development of combined type ADHD: evidence for a synapse-based model. *Am J Med Genet B Neuropsychiatr Genet*. Dec 5 2007;144B(8):971-975.
257. Purcell S. Variance components models for gene-environment interaction in twin analysis. *Twin research : the official journal of the International Society for Twin Studies*. Dec 2002;5(6):554-571.
258. Thomas D. Gene--environment-wide association studies: emerging approaches. *Nat Rev Genet*. Apr 2010;11(4):259-272.